

MediTrackPro: A Robust Platform for Efficient Medicine Stock and Information Management

Shreya Patle¹, Shreya Mate², Prof. Anupam Chaube³

^{1,2,3,4}Department of Science and Technology,

^{1,2}G H Raisoni Institute of Engineering and Technology, Nagpur, Maharashtra, India

³G H Raisoni College of Engineering and Management, Nagpur, Maharashtra, India

ABSTRACT

Pharmaceutical inventory management is crucial to guaranteeing the timely supply of medications to consumers, hospitals, and clinics. This article describes the design, development, and deployment of StockMeds, an online pharmaceutical stock management system. StockMeds helps pharmacies, hospitals, and distributors to properly manage their inventory, track it in real time, estimate demand, and expedite procurement procedures. This system is intended to solve issues such as stockouts, overstocking, expiry tracking, and counterfeit pharmaceuticals. The paper goes into the system architecture, database design, major features, and possible advantages for pharmaceutical companies and healthcare providers.

KEYWORDS: *Pharmaceutical practices, Platform, Inventory Management, Hospital Pharmacy, Community Pharmacy, Drug regulation*

I. INTRODUCTION

In the Fast-moving healthcare field, the accuracy and efficiency of the medication process management to ensure patient safety and Improving patient health results has become foremost. In between prescribers and patients, the pharmacies play a fundamental role in the integration of medication distribution and administration. The implementation of traditional pharmacy operations often have to face numerous challenges, including manual errors, lack of real-time inventory tracking, limited interoperability with other healthcare systems. These compromises significantly reduces the efficiency and pose a risk of patient well-being. Thus including an automated pharmacy management system comes out to be promising approach to these long- standing issues, changing the way pharmacies operate and interact with the broader healthcare ecosystem.

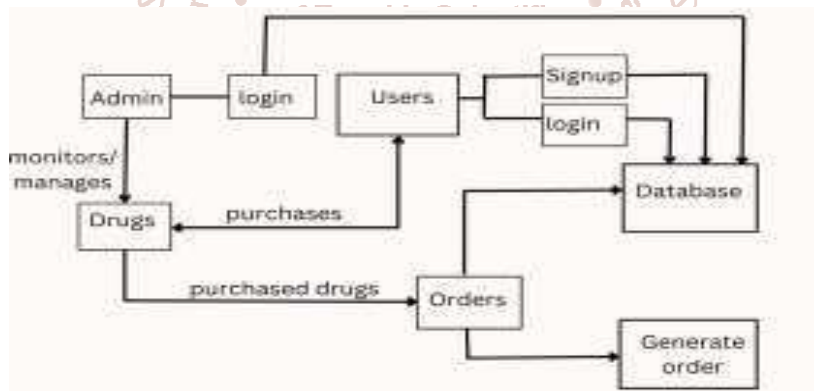

Fig 1: Block diagram of pharmacy Management

The main goal of the system is to develop and propose a strong pharmacy management system that will improve inventory control, expedite pharmacy operations, and integrate with electronic health records (EHRs). By utilizing these technologies, our system seeks to reduce pharmaceutical mistakes and maximize stock levels in this rapidly expanding era of automation and data analytics. As a consolidated platform, our technology will let pharmacists effectively handle prescriptions, maintain drug data, and monitor inventory levels in real time.

The pharmacy management system streamlines the entire medication management process by integrating a centralized database, pharmacists (administrators), and patients (users) in a seamless manner. Figure 1 provides an example of this thorough integration. Patients are given access to an authorized user interface that allows them to easily make orders and peruse the available drug inventory.

II. LITERATURE SURVEY

Pharmaceutical administration has become increasingly important in the sphere of contemporary healthcare in this rapidly expanding period, guaranteeing appropriate inventory control and handling of prescriptions across many pharmacy organizations. These management systems are the result of the efforts of several researchers.

In his book "Pharmaceutical Automation: Algorithms and Drug Dispensation," Carlisle George [2012] discussed algorithms for effective medication issuance, patient monitoring, and control mechanisms, among many other ideas. Given the enormous growth of the Internet of Things (IOT), Agrawal et al. (2017) and Smith and colleagues (2018) developed a method for hospital department services and mapping the current condition of hospital pharmacy operations.

Recognizing the need for interoperability, Jones [2019] introduced a framework to integrate the pharmacy management system (PMS) with the electronic medical record (EMR) systems. Thus, it helped in improvement of data security and management of medical record, Not only that the framework introduced many more innovative ideas by several people in the era of Artificial Intelligence (AI) and Machine Learning (ML). Also, Chen et al. [2020] introduced robotic dispensing system, where Artificial Intelligence (AI) with automation was combined to demonstrate a streamline medication processes. Furthermore, more recently Juan Gonzalez [2023] investigated on the impact of mobile applications on the Patient Medication adherence (signifies that the patient and physician collaborate to improve the patient’s health) and patient engagement within pharmacy management systems. Similarly, Emily Davis [2023] focused on the integration of blockchain technology for secure and transparent medication supply chain management

These contributions have covered a range of topics related to pharmacy administration, such as patient safety, automation, inventory control, interoperability, and the implementation of new technology. More study and innovation in this field will be essential for improving drug management procedures and patient care in general as healthcare needs continue to change.

III. PROPOSED WORK

Our goal is to automate different pharmacy procedures in order to lower the possibility of human mistake, guarantee accurate inventory management, and maintain patient records utilizing a graphical user interface. Interoperability has been given top priority in this project, allowing for smooth interaction with electronic medical records (EMRs). This project allows the user to maintain their profile by choosing the dosage of medication that the doctor has recommended and creating a list of it. Additionally, the authentication system is appropriately built to improve patient data protection from any unauthorized individuals. The suggested system is broken up into several modules and serves the needs of consumers, administrators, medications, and orders.

The backend where the data is managed is done by SQL Server database, it provides reliability. The graphical user interface(GUI) is designed to be simple and user-friendly for the user to interact freely. The main technology which forms the root of the proposed system is done by python programming language, and streamlit for the web application framework. These technology stack combine make a robust system for inventory management, patient record management, billing and claims processing, reporting and analytics.

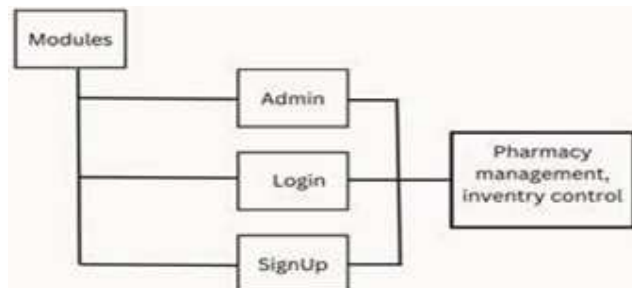

Fig.2: Different modules in system

The Streamlit web app may be accessed through the application's primary hub, which also has a sidebar menu for

easy navigation. Options like "Login," "SignUp," and "Admin" are among the options in this sidebar menu that are specific to particular user roles and tasks. The program dynamically adjusts to offer particular functions based on the user's selection:

Admin

Administrators have the ability to add, view, update, and remove drugs from the system's database. They can also access and manage customer details, as well as review and oversee order information.

Login

Registered customers, upon successfully logging in, gain access to a personalized view of their inventory, order history and can easily browse through many more medicines and add it into its inventory and perform various operations.

Signup

New users can easily create an account by navigating to the "Sign Up" option.

IV. SYSTEM ARCHITECTURE

Our system's design is layered and modular to guarantee scalability and effective database administration. Because it is a web application, it may be accessed from a variety of devices and places. The database component, which sits at the heart of the system, is utilized to store and handle all of the information pertaining to patients, orders, inventories, and medications.

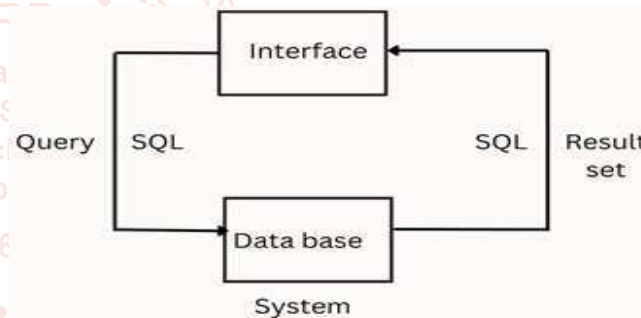

Fig 3: Client-server architecture

Figure 3 shows that the database component follows the client – server architecture where the interface acts as the intermediary in between the user and the database. The user fires the SQL queries through the interface, which then communicates with the Database to execute the queries and retrieve or update the requested data. This type of architecture ensures the abstraction of data and separates the Interface layer handling user interactions, the Database layer managing data storage and retrieval and ensures the data integrity.

V. PERFORMANCE EVALUATION

The Pharmacy Management System offers the ability to effectively manage operations linked to pharmaceuticals. Its primary focus is on providing pharmacies with high-quality delivery.

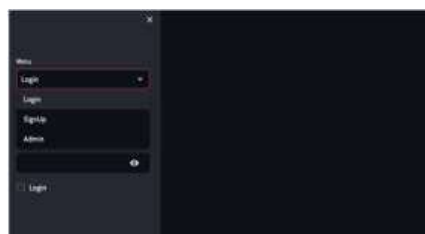

Fig 4: Designed UI

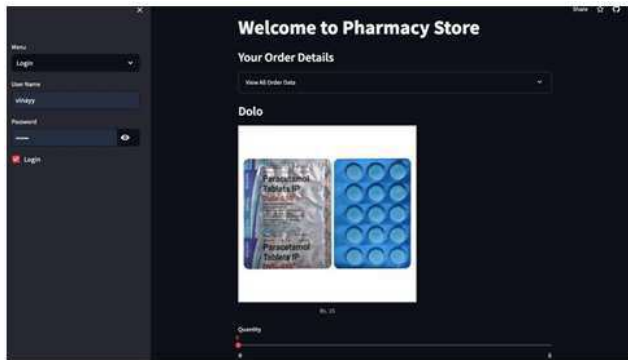

Fig 5: Homepage

The user will enter the application after successfully logging in. Numerous medications that may be ordered are shown here. There are instructions on how and when to utilize medications. By choosing "buy now," the user may choose the medications and their amount, then place their order. The user may then download the.csv file with the prescribed medication specifics and review the order data.

The results obtained from research and system deployment are as follows:

1. Inventory Management

- Keeps track of medicines, medical supplies and other products stocked by pharmacy.
- The system helps in managing pharmacy in the terms of stock levels, reordering of medicines and expiration of medicines.

2. Patient Safety

- The system reduces mistakes by giving information about possible medication interactions and dose disparities, along with when to use it.
- Pharmacy professionals may use it to correctly check prescriptions and reduce patient hazards.

3. Analytics-Driven Decision Making

- Pharmacy managers may easily analyze and make choices based on real-time data by using the reports generated by the pharmacy management program.
- It would be evident from analyzing sales data how much inventory we have, how much should be ordered, how many prescriptions are being filled, etc.

4. User Satisfaction

- The app significantly increased accuracy, sped up service, and enhanced communication.
- One of the most notable benefits is that patients now have to wait less time and may readily obtain their drugs, which increases patient satisfaction.
- Pharmacy management systems help pharmacists by streamlining processes and cutting down on time spent on manual operations like maintaining inventory and writing prescriptions.

VI. CONCLUSION

In conclusion, it is evident that improvements in pharmaceutical operations and services were made possible by the deployment of the Pharmacy Management System. Additionally, it offers an automated and computerized version of the Pharmacy Management System. Future modifications may be made with ease because to the application's design. The entire pharmaceutical administration process is done online, which makes it easier to use and has increased productivity because of automation.

By granting access to authorized users based on their kind, it preserves system and data security. It successfully eliminates the need for manual paperwork. Changes brought about by the Pharmacy Management System's growth are advantageous to both pharmacies and users. We anticipate using the application going ahead to offer efficient, safe and high-quality pharmacy services.

REFERENCES

- [1] Carlisle George, "Hospital Pharmacy Management", Management Science of Health, 2012 (Book).
- [2] Basile Spyropoulos, Incorporating the Internet of Things in the Modern Hospital: Attempting a "Taxonomy" of Pertinent Equipment and Services, American Journal of Management Science and Engineering.
- [3] Ratsimbazafimahefa HR., Sadeghipour F., Trouiller P. et al., "Description and analysis of hospital pharmacies in Madagascar", Annales Pharmaceutiques Francaises, 2018.
- [4] Priya, R., Kumari, S., & Kumar, A. (2022). Research on Pharmacy management. Research Gate. https://www.researchgate.net/publication/360963051_Research_on_Pharmacy_management.
- [5] Khudhur, Saja. (2018). HOSPITAL PHARMACY MANAGEMENT SYSTEM. Iraqi Journal for Computers and Informatics. 44. 10.25195/2017/4425.
- [6] Data Professor. (2020, June 12). How to build a simple machine learning web app in Python - streamlit tutorial #2 [Video]. YouTube: <https://www.youtube.com/watch?v=8M20LyCZDOY>
- [7] Risha Patidar, Shohel Akhtar Qureshi, Anash Kuraishi.(2023). Pharmacy Management System. IRJPR. <https://ijrpr.com/uploads/V4ISSUE11/IJRPR19321.pdf>
- [8] Jimmy, B., & José, J. (2011). Patient medication adherence: measures in daily practice. Oman Medical Journal, 26(3), 155-159. <https://doi.org/10.5001/omj.2011.38>.
- [9] Bao, L., Wang, Y., Shang, T., Ren, X., & Ma, R. (2013). A novel clinical pharmacy management system in improving the rational drug use in Department of General Surgery. Indian Journal of Pharmaceutical Sciences/Indian Journal of Pharmaceutical Sciences, 75(1),11. <https://doi.org/10.4103/0250-474x.113531>
- [10] Zangana, H.M. (2018). Design an Information Management System for a Pharmacy. IJARCCCE.
- [11] Yurtkuran, Alkin & Emel, Erdal. (2009). Simulation based decision-making for hospital pharmacy management. 1539 - 1546. 10.1109/WSC.2008.4736235.
- [12] Alanazi, A., Rabiah, F. A., Gadi, H. A., Househ, M., & Dosari, B. A. (2018). Factors influencing pharmacists' intentions to use Pharmacy Information Systems. Informatics in Medicine Unlocked, 11, 1-8. <https://doi.org/10.1016/j.imu.2018.02.004>
- [13] Ayad K. Ali. Inventory Management in Pharmacy Practice: A Review of Literature. Archives of Pharmacy Practice. 2011; 2(4) pp 151-156