

# Enhancing Solar Photovoltaic System Efficiency: A Comparative Analysis of Intelligent ANN-P&O MPPT Controller against Traditional Algorithms

Bashab Mazumder<sup>1</sup>, Samina Elyas Mubeen<sup>2</sup>

<sup>1</sup>M Tech Scholar, Radharaman Engineering College, Bhopal, Madhya Pradesh, India

<sup>2</sup>Associate Professor, Radharaman Engineering College, Bhopal, Madhya Pradesh, India

## ABSTRACT

Solar energy is a potential energy source in India and its application is ever increasing. In solar PV application, the photovoltaic module is needed to harvest this kind of energy. The PV module exhibit nonlinear I–V and P– V characteristics. The maximum power produced varies with both irradiance and temperature. The maximum efficiency is achieved when PV works at its maximum power point which can be obtained by using suitable MPPT algorithm. Most of PV systems use conventional MPPT methods such as incremental conductance (IC) and perturb and observe (P and O). With the advanced in control technology, the intelligent control techniques are commonly used in all areas. A conventional MPPT controller is used to maximise the conversion efficiency under normal conditions but fails in abnormal conditions. This paper proposes an intelligent ANN-P&O MPPT controller for the Boost converter that utilises the effective regions of both ANN and P&O methods to identify the global maximum point in order to improve the conversion efficiency of a PV system and a comparative simulation study of three MPPT algorithms specifically (i) perturb and observe, (ii) artificial neural network (ANN), and (iii) NN – P&O. MATLAB/SIMULINK software is used to test how well the controller works in unusual situations and compare it to its individual counterparts.

**KEYWORDS:** Maximum Power Point Tracking, Perturb and Observe Method, ANN Method, Boost Converter, Hybrid NN – P&O

## I. INTRODUCTION

Spotless and sustainable power sources like photovoltaic (PV) control is played a significant job in electric power age, and become basic nowadays because of deficiency and natural effects of customary powers. The sunlight-based vitality is straightforwardly changed over into electrical vitality by sun based photovoltaic modules. As a result of nonlinear I-V and PV qualities of PV sources, their yield power is principally relied on the ecological conditions and nature of burden associated. Thus, these conditions will be influenced the general productivity of the PV frameworks [1]. But the productivity of the sun-based PV module is low. Because of the mind-boggling expense of sun-based cells, a most extreme power point tracker is expected to work the PV cluster at its greatest power point. Subsequently the greatest power is extricated from the PV generator depends on three variables:

insolation, load profile (load impedance) and cell temperature (surrounding temperature). To get the most extreme power from PV, a greatest power point tracker (MPPT) is utilized [2]. There are so many methods and algorithms for tracking of the MPP of the PV systems. In this paper, comparative investigations of Perturb and observe (P&O) algorithm and artificial neural network (ANN) technique algorithm using dc-dc converter is done in terms of the maximum power transfer capability of these algorithms.

## II. STAND -ALONE SOLAR POWER SYSTEM

The solar PV system consists of a PV module, the dc/dc boost converter, the maximum power point tracking algorithm and the load. Radiation (R) is incident on the PV module. It generates a voltage (V)

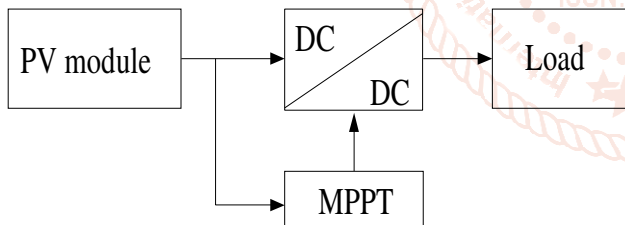
**How to cite this paper:** Bashab Mazumder | Samina Elyas Mubeen "Enhancing Solar Photovoltaic System Efficiency: A Comparative Analysis of Intelligent ANN-P&O MPPT Controller against Traditional Algorithms" Published in International Journal of Trend in Scientific Research and Development (ijtsrd), ISSN: 2456-6470, Volume-8 | Issue-1, February 2024, pp.24-33, URL: www.ijtsrd.com/papers/ijtsrd61318.pdf



Copyright © 2024 by author (s) and International Journal of Trend in Scientific Research and Development Journal. This is an Open Access article distributed under the terms of the Creative Commons Attribution License (CC BY 4.0) (<http://creativecommons.org/licenses/by/4.0>)



and current (I) which will be fed into the load [3]. The voltage power characteristic of a photovoltaic (PV) array is nonlinear and time varying because of the changes caused by the atmospheric conditions. When the solar radiation and temperature varies the output power of the PV module also changes. In order to obtain the maximum efficiency of the PV module, it must operate at the maximum point of the PV characteristic. The most extreme power point relies upon the temperature and irradiance which are non-direct in nature. The greatest power point following control framework is utilized and work viability on the non-straight varieties in the parameters, such as temperature and radiations [4]. A MPPT is used for extracting the maximum power from the solar PV module and transferring that power to the load. A dc/dc converter (boost converter) serves the purpose of transferring maximum power from the solar PV module to the load. A dc/dc converter acts as an interface between the load and the module. The dc/dc converter with maximum power point tracking algorithm and the load is shown in Fig. 1. By changing the duty cycle, the load impedance as seen by the source is varied and matched at the point of the peak power with the source so as to transfer the maximum power. Therefore, MPPT techniques are needed to maintain the PV array's operating at its MPP [3]. In this paper, two most popular of MPPT technique (Perturb and Observe (P&O) methods and artificial neural network (ANN) methods and dc-dc converter will be involved in comparative study.



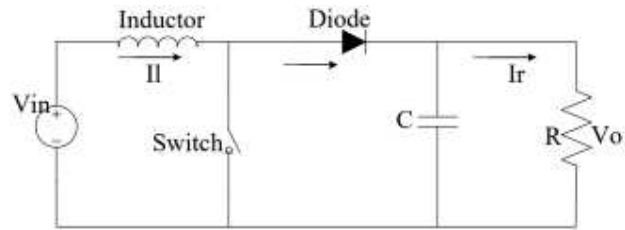
**Fig. 1: Block Diagram of PV System with MPPT**

### III. MAXIMUM POWER POINT TRACKING

Most extreme Power Point Tracking (MPPT) is helpful apparatus in PV application. Sun oriented radiation and temperature are the primary factor for which the electric power provided by a photovoltaic framework. The voltage at which PV module can create greatest power is called 'most extreme power point (pinnacle control voltage). The primary rule of MPPT is in charge of separating the greatest conceivable power from the photovoltaic and feed it to the heap by means of dc-to-dc converter which steps up/ down the voltage to required size [5]. There are many maximum power point techniques. Among them, two MPPT techniques of ANN, perturb and observe (P&O) have been selected for the purpose of comparison in this paper.

### A. DC/DC Boost Converter

The dc-dc converter is used to supply a regulated dc output with the given dc input. These are widely used as an interface between the photovoltaic panel and the load in photovoltaic generating systems. The load must be adjusted to match the current and voltage of the solar panel so as to deliver maximum power. The dc/dc converters are described as power electronic switching circuits. It converts one form of voltage to other. These may be applicable for conversion of different voltage levels. Fig.2 shows the circuit diagram of dc-dc boost converter [7].



**Fig. 2: Circuit Diagram of Boost Converter**

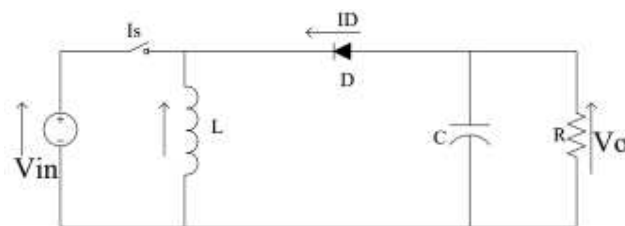
The dc-dc boost converter circuit consists of Inductor (L), Diode (D), Capacitor (C), load resistor (RL), the control switch(S). These components are connected in such a way with the input voltage source (Vin) so as to step up the voltage. The output voltage of the boost converter is controlled by the duty cycle of the switch. Hence by varying the ON time of the switch, the output voltage can be varied. The relationships of input voltage, output voltage and duty cycle are as follow:

$$\frac{V_o}{V_{in}} = \frac{1}{1-D} \quad (1)$$

Where,  $V_{in}$ ,  $V_o$  are the input and output voltage of the converter and D is the duty cycle of the control switch.

### B. DC/DC Buck-Boost Converter

A buck-boost converter is a type of dc-dc converter that has an output voltage magnitude either greater than or less than the magnitude of the input voltage magnitude. It's described by a voltage source connected in parallel to an inductor, a reverse-biased free-wheeling diode, a capacitor, and a load of resistance R at the output terminal. In MPPT with ANN technique,  $V_{mppt}$  will be lower than the input voltages in some conditions. Thus buck/boost converter is more favorable than boost converter for ANN technique [7].



**Fig. 3: Circuit Diagram of Boost Converter**

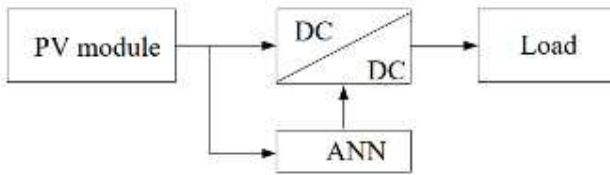
$$\frac{V_o}{V_{in}} = \frac{D}{1-D} \quad (2)$$

Where,  $V_{in}$ ,  $V_o$  are the input and output voltage of the converter and  $D$  is the duty cycle of the control switch.

**C. ANN Technique**

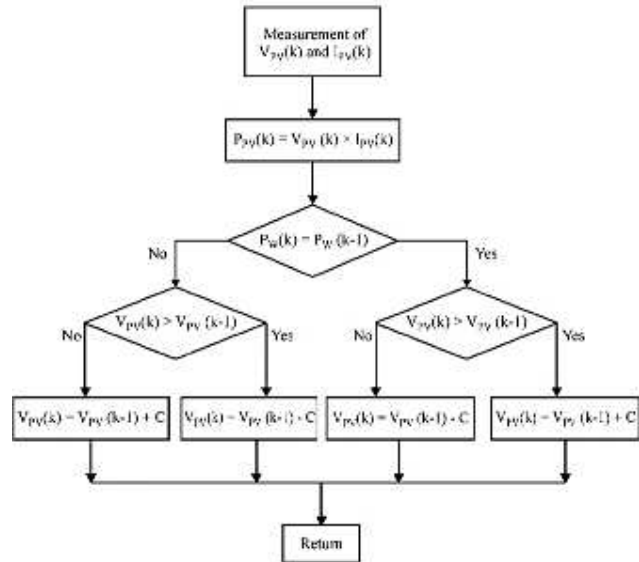
The ANN control system has to be trained before being used in the photovoltaic system. The neural network is a powerful technique for mapping the input-output nonlinear function. The network tries to simulate its learning process through the various input fed to it during each cycle of data interpretation. It changes its structure based on the internal and external information that flows in and out of the network system.

The ANN control framework must be prepared before being utilized in the photovoltaic framework. The neural system is an incredible method for mapping the info yield nonlinear capacity. In the proposed structure, a two-layer falling neural system method is fused that predicts the PV exhibit voltage at which the most extreme power is achievable. These build up a non-direct connection between the information and yield with a concealed layer that capacities with inclinations like neurons of our mind. The hidden layer in the model is a two-layer neural network. This is then sent to layer 1 with 50 neurons where a process input synthesizes the signal with weights and generates a tangent sigmoid transfer function. The output of layer 1 is the input for layer 2 with another set of 50 neurons that assigns weightage to the values and generates a pure linear transfer function [8].



**Fig. 4: MPPT System with ANN Controller**

**D. Perturb and Observe (P&O) Technique**

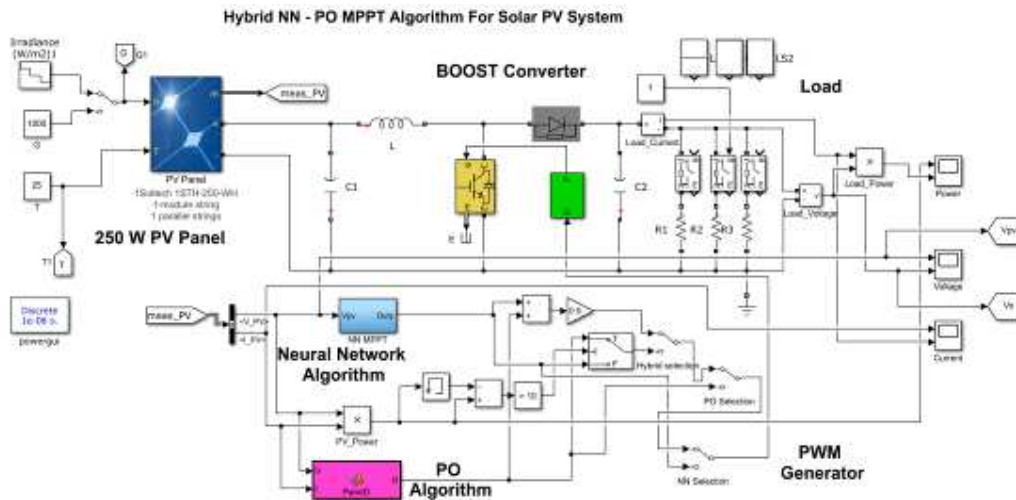


**Fig. 5 State-flow Chart of P&O MPPT Technique**

P&O is the most often utilized method to follow the greatest power because of its straightforward structure. This method works by intermittently irritating the PV module terminal voltage and contrasting the PV yield control and that of the past annoyance cycle [1]. As shown in Fig. 5 if the PV module operating voltage changes and power increases the control system moves the operating point in that direction; otherwise, the operating point is moved in the opposite direction.

**IV. SIMULATION AND RESULTS**

After modeling the Stand-Alone PV System, the comparative analysis of Maximum Power Point Tracking Algorithms is analyzed. The simulation models for Maximum Power Point Tracking Algorithms are executed with MATLAB/Simulink version R2021A. The simulation results of Maximum Power Point Tracking Algorithms for all the schemes are shown in the following sections.



**Fig 6. MATLAB/ Simulink Hybrid NN – P&O MPPT Algorithm for Solar PV System**

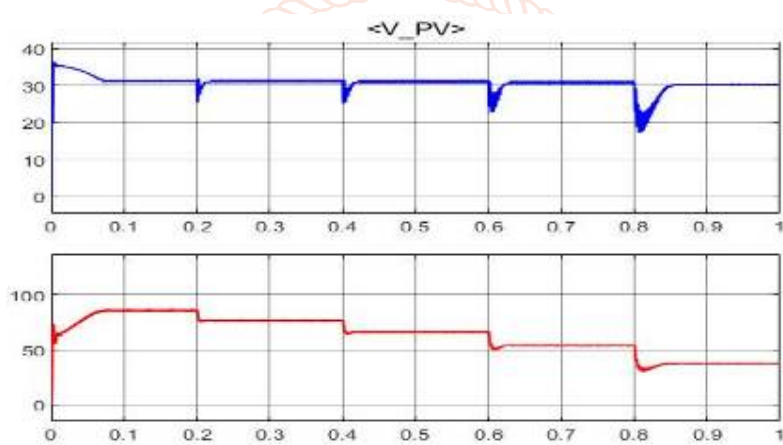
To analyze the performance of the output voltages, the output currents and the output power are measured as shown. The PV parameters of the system are shown in Table I.

**TABLE I: PV PARAMETERS**

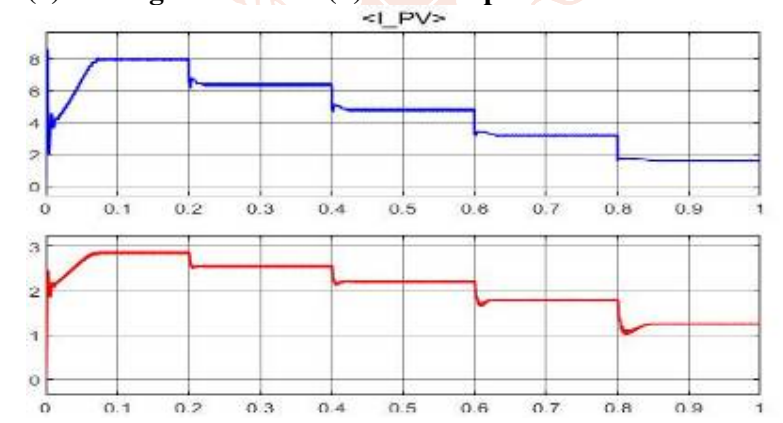
Parameters	Specifications
Maximum power, $P_m$	250 W
Series-connected modules per string	1 nos
Parallel strings	1 nos
Cells per module (Ncell)	60
Maximum power voltage, $V_{pm}$	30.7 V
Maximum power current, $I_{pm}$	8.15 A
Open circuit voltage, $V_{oc}$	37.3V
Short circuit current, $I_{sc}$	8.66A

**A. Simulation Results with Different Algorithms**

For comparative study with different algorithms, three algorithms are applied for MPP tracking in this research as (i) Perturb and Observe (P and O) method, (ii) ANN method And NN – P&O. The simulation results for different algorithms under variation in irradiance condition, 1000, 800, 600, 400, 200  $W/m^2$  (IR) and Constant Temperature Condition 25°C (T) are shown in the following figures.

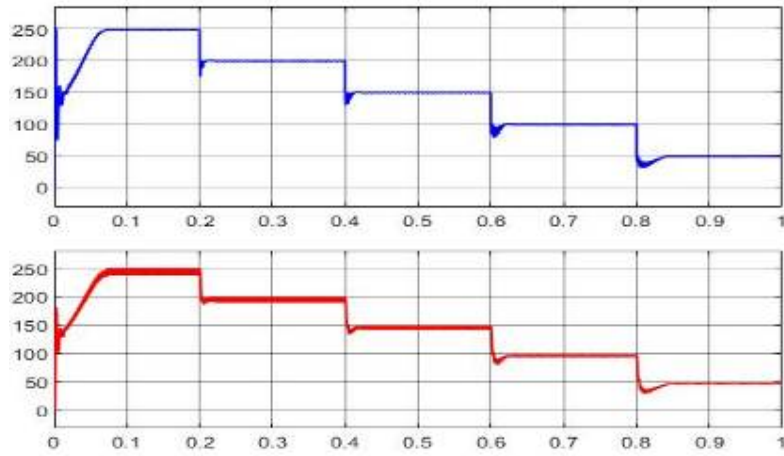


**Fig 7 (a): Voltage vs Time in (S) in correspondence with P&O Method.**

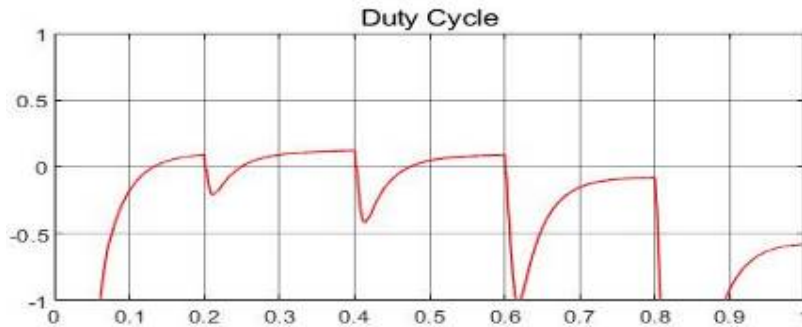


**Fig 7 (b): Current vs Time in (S) in correspondence with P&O Method.**

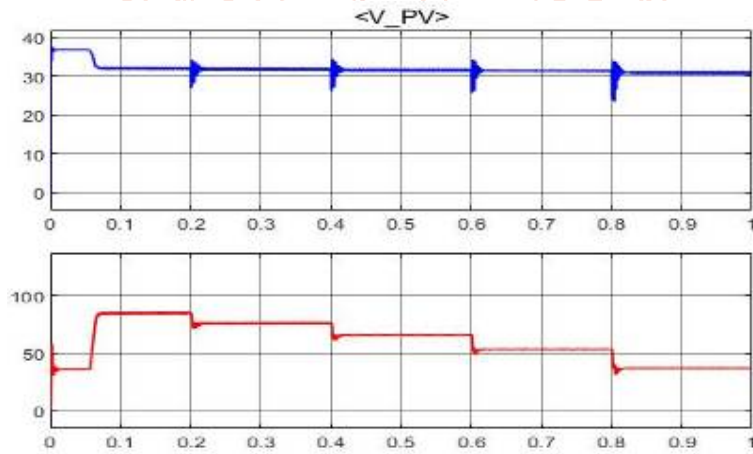




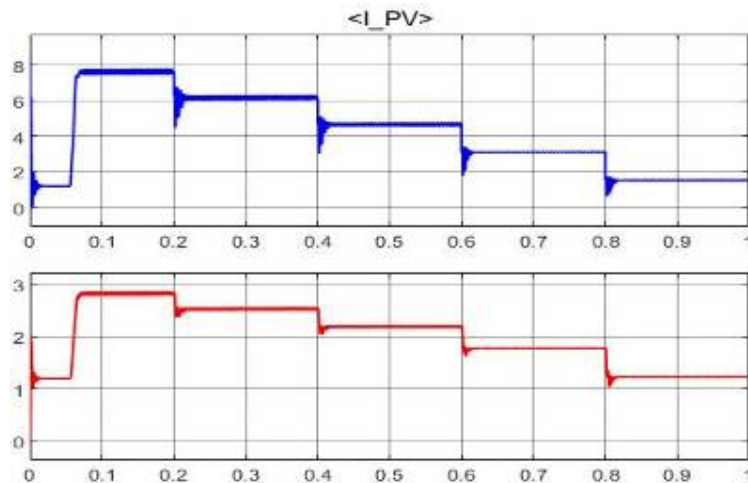
**Fig 7 (c): Power vs Time in (S) in correspondence with P&O Method.**



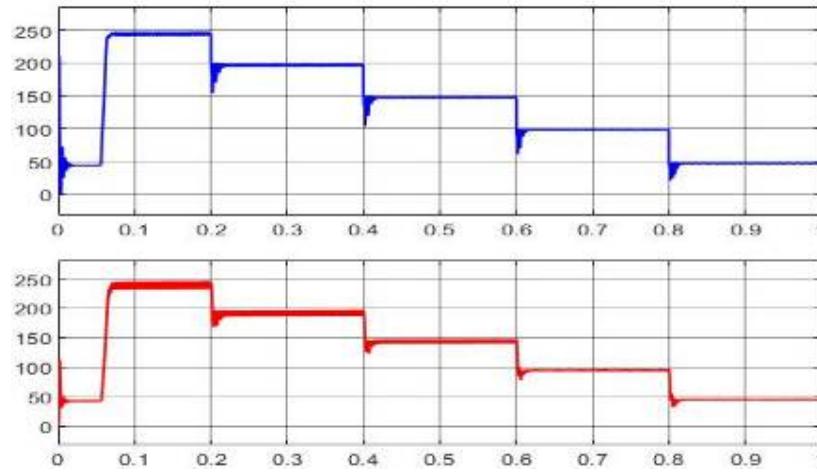
**Fig 7 (d): Duty Cycle vs Time in (S) in correspondence with P&O Method.**



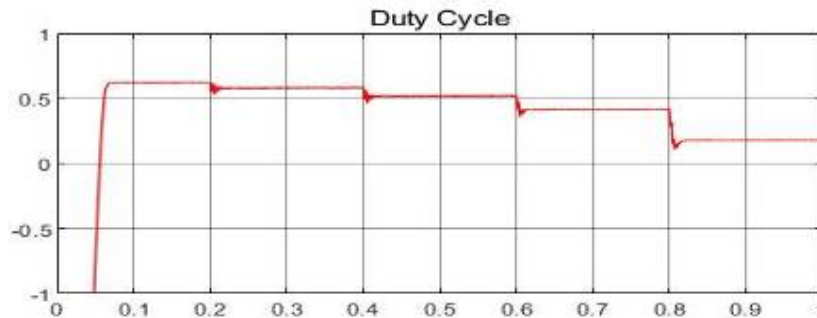
**Fig 8 (a): Voltage vs Time in (S) in correspondence with ANN Method.**



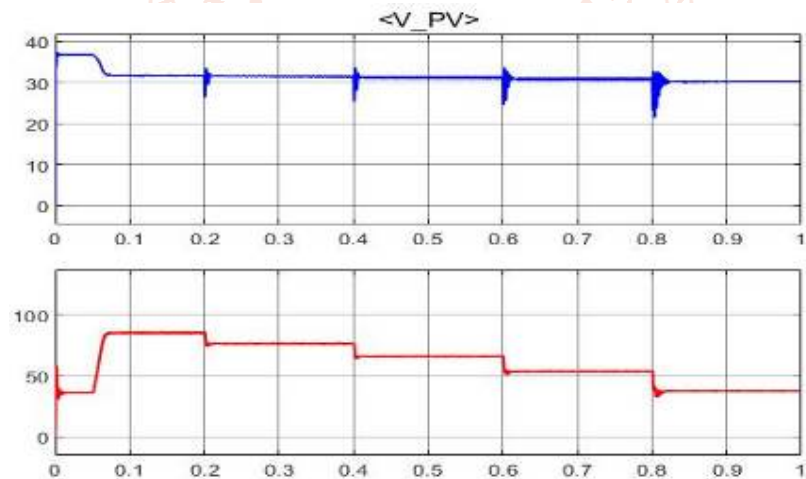
**Fig 8 (b): Current vs Time in (S) in correspondence with ANN Method.**



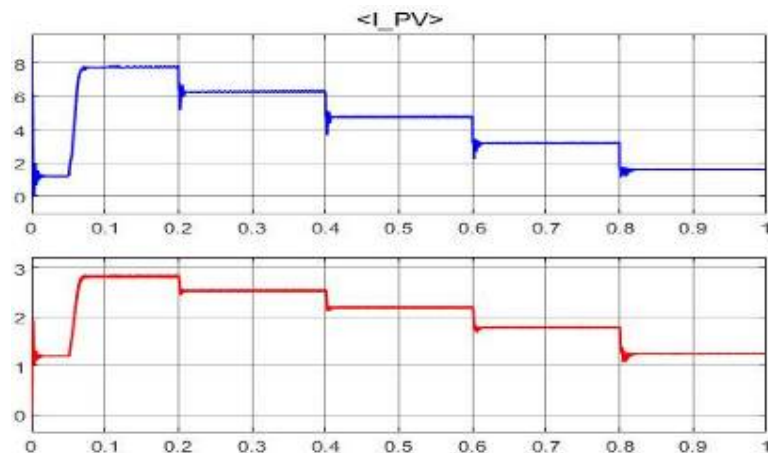
**Fig 8 (c): Power vs Time in (S) in correspondence with ANN Method.**



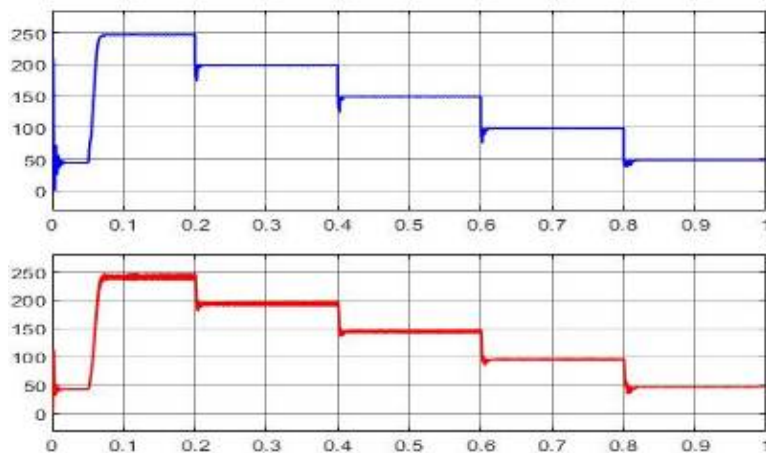
**Fig 8 (d): Duty Cycle vs Time in (S) in correspondence with ANN Method.**



**Fig 9 (a): Voltage vs Time in (S) in correspondence with NN – P&O Method.**



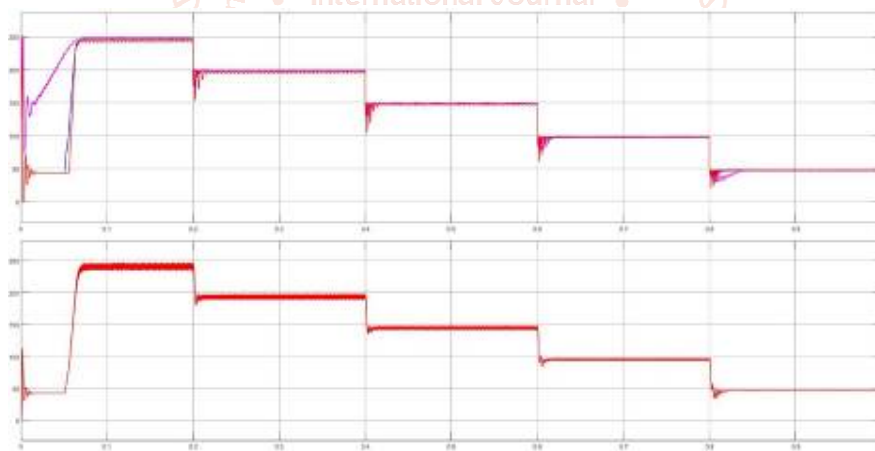
**Fig 9 (b): Current vs Time in (S) in correspondence with NN – P&O Method.**



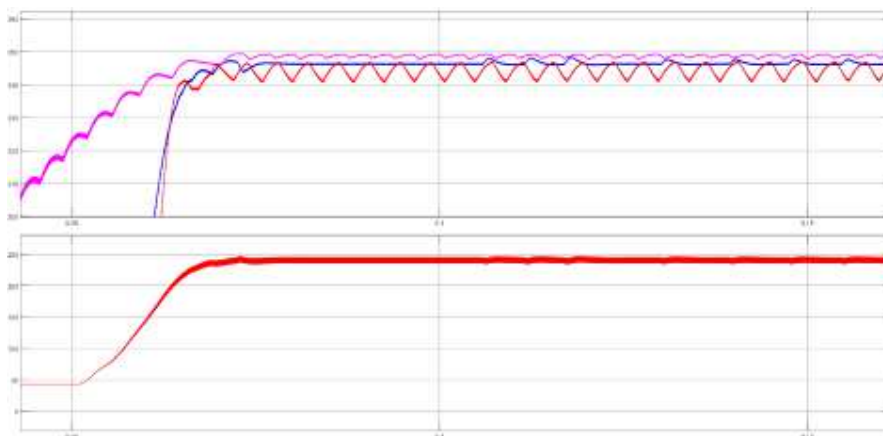
**Fig 9 (c): Power vs Time in (S) in correspondence with NN – P&O Method.**



**Fig 9 (d): Duty Cycle vs Time in (S) in correspondence with NN – P&O Method.**



**Fig 10 (a): Shows Comparison Between all three techniques**



**Fig 10 (b): Shows Brief Comparison Between all three techniques**

Fig. 10 (a) & (b) shows comparison for power output under variation in irradiance condition, 1000, 800, 600, 400, 200 W/m<sup>2</sup> (IR) and Constant Temperature Condition 25°C (T). According to this Fig. 10 (a) & (b), the power provided and the transient performance by Hybrid NN – P&O is better compared to P and O method and ANN Method.

### B. Simulation Result Comparisons of MPPT Techniques

The simulation results of output voltage, output current, and output power under standard irradiance condition, 1000 W/m<sup>2</sup> (IR) and Constant Temperature Condition 25°C (T) are shown in Table II. According to the simulation results, in comparison of the three output powers, the power provided by NN – P&O technique is larger in 1000 W/m<sup>2</sup> irradiation case.

**TABLE II: COMPARISON OF SIMULATION RESULTS FOR 1000 W/m<sup>2</sup> IRRADIATION**

Irradiation (W/m <sup>2</sup> )	Parameter	Algorithm		
		ANN	P and O	Hybrid NN – P&O
1000	V <sub>o</sub> (V)	29.8	28.9	30.5
	I <sub>o</sub> (A)	8.0438	8.0096	8.0596
	P <sub>o</sub> (W)	249.1	248.9	249.8

The simulation results of output voltage, output current and output power for Constant Temperature Condition 25°C (T) are shown in Table III.

**TABLE III: COMPARISON OF SIMULATION RESULTS FOR 25°C TEMPERATURE**

Temperature (°C)	Parameter	Algorithm		
		ANN	P and O	Hybrid NN – P&O
25	V <sub>o</sub> (V)	29.8	28.9	30.5
	I <sub>o</sub> (A)	8.0438	8.0096	8.0596
	P <sub>o</sub> (W)	249.1	248.9	249.8

According to the simulation results. In comparison of the other two output powers, the power provided by NN – P&O technique is larger in the 25°C temperature case.

### V. Conclusions

Simulation results for ANN, P&O, and Hybrid NN–P&O methods presented in this thesis show that the Hybrid ANN-P&O controller tracks the Maximum Power Point (MPP) quickly compared to the individual P&O controller and ANN controller. The NN–P&O method is very fast and precise in finding and tracking the MPP in the case of rapidly changing solar irradiation. Furthermore, this method can stably extract the maximum power point under slowly changing solar irradiation, and efficiency is better with the combination of the improved P&O-ANN method. On the other hand, the ANN method can maintain its output voltage close to its maximum power voltage (V<sub>mp</sub>) and thus can provide more power than the P and O methods. Again, the ANN technique exhibits better transient response and reaches steady state conditions more quickly. On the contrary, when irradiation changes fast in a short time, the P & O method fails to track the MPP. Also, this method has high oscillation around MPP under slow changing solar irradiation, which leads to high power loss in the long term.

### VI. Future Scope

➤ The possibility to combine two or more renewable energy sources, based on the natural local potential of the users.

- Combinations of algorithms and controllers, like PSO, GA, Fuzzy Logic, and ANFIS, can be used to make PV systems work more efficiently.
- Environmental protection especially in terms of carbon dioxide emissions reduction.
- Low-cost wind energy and solar energy can be competitive with nuclear, coal, and gas energy, especially considering possible future cost trends for fossil and nuclear energy. Diversity and security of supply Quick deployment: modular and easy to install.

### References

- [1] PH Heera; V. Mini “Solar Photovoltaic System with Power Quality Improvement” 2020 International Conference on Power Electronics and Renewable Energy Applications (PEREA).
- [2] Julio Fredy Chura Acero; Henry Pizarro Viveros; Norman Jesús Beltrán Castañón; Reynaldo Condori Yucra “Improvement of Power Quality for Operation of the Grid-Connected Photovoltaic Energy System Considering the Irradiance Uncertainty” 2020 IEEE XXVII International Conference on Electronics, Electrical Engineering and Computing (INTERCON).



- [3] Bhagyashree Parija; Santi Behera; Ruturaj Pattanayak; Sasmita Behera "Power Quality Improvement in Hybrid Power System using D-STATCOM" 2019 3rd International Conference on Computing Methodologies and Communication (ICCMC).
- [4] Nirav Patel; Nitin Gupta; B. Chitti Babu" Multifunctional VSC Controlled Solar Photovoltaic System with Active Power Sharing and Power Quality (PQ) Improvement Features" 2019 IEEE 1st International Conference on Energy, Systems and Information Processing (ICESIP).
- [5] Tripurari Nath Gupta; Shadab Murshid; Bhim Singh" Single-Phase Grid Interfaced Hybrid Solar PV and Wind System using STF-FLL for Power Quality Improvement" 2018 8th IEEE India International Conference on Power Electronics (IICPE).
- [6] Varsha Rani; Om Prakash Mahela; Himanshu Doraya "Power Quality Improvement in the Distribution Network with Solar Energy Penetration Using Distribution Static Compensator" 2018 International Conference on Computing, Power and Communication Technologies (GUCON).
- [7] Ravi Dharavath; I. Jacob Raglend; Atul Manmohan "Implementation of solar PV — Battery storage with DVR for power quality improvement" 2017 Innovations in Power and Advanced Computing Technologies (i-PACT).
- [8] Priyank Shah; Ikhlq Hussain; Bhim Singh "Power quality improvement of grid interfaced solar PV using adaptive line enhancer based control scheme" 2017 6th International Conference on Computer Applications In Electrical Engineering-Recent Advances (CERA).
- [9] Jayasankar V N; Vinatha U "Implementation of adaptive fuzzy controller in a grid connected wind-solar hybrid energy system with power quality improvement features" 2016 Biennial International Conference on Power and Energy Systems: Towards Sustainable Energy (PESTSE).
- [10] Rajan Kumar; Bhim Singh "Grid interfaced solar PV powered brushless DC motor driven water pumping system" 2016 7th India International Conference on Power Electronics (IICPE).
- [11] G. Cipriani, V. D. Dio, F. Genduso, R. Miceli and D. L. Cascia, "A new modified Inc-Cond MPPT technique and its testing in a whole PV simulator under PSC," in Proc. of the 2015 IEEE Applied Power Electronics Conference and Exposition (APEC), Charlotte, NC, pp. 3060- 3066.
- [12] S. K. Ji, H. Y. Kim, S. S. Hong, Y. W. Kim and S. K. Han, "Nonoscillation Maximum Power Point Tracking algorithm for Photovoltaic applications," in Proc. of the 2014 Power Electronics and ECCE Asia (ICPE & ECCE), Jeju, pp. 380-385.
- [13] Yi-Hsun Chiu, Yu-Shan Cheng, Yi-Hua Liu, Shun-Chung Wang and ZongZhen Yang, "A novel asymmetrical FLC-based MPPT technique for photovoltaic generation system," in Proc. of the 2014 International Power Electronics Conference (IPEC-Hiroshima 2014 - ECCE ASIA), Hiroshima, pp. 3778-3783.
- [14] S. Dwari, L. Arnedo, S. Oggianu and V. Blasko, "An advanced high performance maximum power point tracking technique for photovoltaic systems," in Proc. of the 2013 IEEE Applied Power Electronics Conference and Exposition (APEC), Long Beach, CA, 2013, pp. 3011- 3015.
- [15] N. Mendis, K. M. Muttaqi, S. Sayeef and S. Perera, "Standalone Operation of Wind Turbine-Based Variable Speed Generators With Maximum Power Extraction Capability," IEEE Transactions on Energy Conversion, vol. 27, no. 4, pp. 822-834, Dec. 2012.
- [16] S. Poshtkouhi and O. Trescases, "Multi-input single-inductor dc-dc converter for MPPT in parallel-connected photovoltaic applications," in Proc. of the 2011 IEEE Applied Power Electronics Conference and Exposition (APEC), Fort Worth, TX, pp. 41-47.
- [17] I. Colak, E. Kabalci and G. Bal, "Parallel DC-AC conversion system based on separate solar farms with MPPT control," in Proc. of the 2011 Power Electronics and ECCE Asia (ICPE & ECCE), Jeju, pp. 1469-1475.
- [18] G. Gamboa, J. Elmes, C. Hamilton, J. Baker, M. Pepper and I. Batarseh, "A unity power factor, maximum power point tracking battery charger for low power wind turbines," in Proc. of the 2010 IEEE Applied Power Electronics Conference and Exposition (APEC), Palm Springs, CA, pp. 143-148.
- [19] M. E. Haque, M. Negnevitsky and K. M. Muttaqi, " A novel control strategy for a variable-speed wind turbine with a permanent

- magnet synchronous generator". IEEE Transactions on industry application, vol. 46, no. 1, pp. 331-339, jan/feb 2010.
- [20] M. Kiani, D. Torregrossa, M. Simoes, F. Peyraut and A. Miraoui, "A novel maximum peak power tracking controller for wind energy systems powered by induction generators," in Proc. of the 2009 IEEE Electrical Power & Energy Conference (EPEC), Montreal, QC, pp. 1-3.
- [21] M. Shirazi, A. H. Viki and O. Babayi, "A comparative study of maximum power extraction strategies in PMSG wind turbine system," in Proc. of the 2009 IEEE Electrical Power & Energy Conference (EPEC), Montreal, QC, pp. 1-6.
- [22] H. Patel and V. Agarwal, "Maximum Power Point Tracking Scheme for PV Systems Operating Under Partially Shaded Conditions," IEEE Transactions on Industrial Electronics, vol. 55, no. 4, pp. 1689-1698, April 2008.
- [23] M. E. Haque, K. M. Muttaqi and M. Negnevitsky, "Control of a Stand-alone variable speed wind turbine with a permanent magnet synchronous generator", Proceeding of IEEE power and energy society general meeting, pp. 20-24 july 2008.
- [24] T. Esum and P. L. Chapman, "Comparison of Photovoltaic Array Maximum Power Point Tracking Techniques," IEEE Transactions on Energy Conversion, vol. 22, no. 2, June 2007, pp. 439-449.
- [25] T. F. Chan, L. L. Lai, "permanent magnet machines for distributed generation: a review", Proc. 2007 IEEE power engineering annual meeting, pp. 1-6.
- [26] M. Fatu, L. Tutelea, I. Boldea, R. Teodorescu, "Novel motion sensorless control of stand alone permanent magnet synchronous generator (PMSG) : harmonics and negative sequence voltage compensation under nonlinear load ", 2007 European conference on Power Electronic and Application, 2-5 Sept. 2007.
- [27] D.Sera, R.Teodorescu, and P.Rodriguez, "PV panel model based on datasheet values" ,IEEE International Symposium on Industrial Electronics,ISIE,PP.2392-2396,2007.
- [28] H. Polinder, F.F.A van der Pijl, G.J.de Vilder, P.J.Tavner, "Comparison of direct- drive and geared generator concept for wind turbine ", IEEE Transactions on Energy Conversion, vol., 21, no. 3, pp725-733, Sept. 2006.
- [29] Seul Ki Kim, Eung Sang Kim, Jong Bo Ahn, "Modeling and control of a Grid connected Wind/PV Hybrid Generation System", 2005/2006 IEEE PES Transmission and Distribution Conference and Exhibition,21-24 May 2006,pp.1202-1207.
- [30] Fernando Valencaga, Pablo F. Puleston and Pedro E. Battaiotto, "Power Control of a Solar/Wind Generation System Without Wind Measurement: A Passivity/Sliding Mode Approach", IEEE Trans. Energy Conversion, Vol. 18, No. 4, pp. 501-507, December 2003.