

Design Smart Energy Meter to Prevention of Power Theft and Automatic Billing

Prof. C. J. Sharma, Akash B. Khatik, Apekshit A. Ramteke, Aniket S. Askar

Department Electrical Engineering, K.D.K College of Engineering R.T.M. N.U. Nagpur, Maharashtra, India

ABSTRACT

In developing countries like India, power theft is one of the most prevalent issues which not only cause economic losses but also an irregular supply of electricity. An Electricity meter or Energy Meter is a device that measures the amount of electrical energy consumed by a residence, business or an electrical power device. A Smart Energy Meter to control under voltage or overvoltage and it's prevented power theft in line. The lower range of under voltage is 180 V and the higher range of overvoltage is 280 V and output should be constant between 220 V–240 V is constant continuously. If any consumer meter get bypass or tapping illegally that time connected all the equipment should be damaged with the help of changing the transformer tapping in substation that time the voltage should be more (high) as a rated supply voltage. The transformer changes the tapping time is not fixed in our days; it depends on our supply authority. The energy consumed by the consumer and they paid equivalent amount will be shown on the LED (16*2) display continuously the consumer not paid a monthly bill then after 10 days of month the supply will be disconnect automatically and by consumer paid bill then the informed with the help of supply authority's server.

KEYWORDS: Electricity power theft Prevention, Power Consumption and Voltage Stabilizer

INTRODUCTION

Power theft is major issue of concern these days; bad minded people do power theft through illegal ways such as hanging and by bypassing the electric meter. such power theft causes huge loss of power and economy of the country and to resolve such problems is the task of priority of the government and related to this cause many things has been done so far but there is continuous need of advances as power theft is still continue. The Smart Energy Meter is a device which is used to measure the Consumption of energy of any residential or other Industrial establishment. The technology of electronic metering has gone through rapid technological advertisement and there is increase demand for reliable and efficient automatic meter system. The voltage stabilizer is an electronic circuit or device that is capable of providing a constant or nearly constant output voltage even when there is variation in load or input voltage as a low as 180 V can be boost up to 280 V by stabilizer at output stage without any voltage fluctuation. The purpose of visual studio is used to automatic billing system is to

How to cite this paper: Prof. C. J. Sharma | Akash B. Khatik | Apekshit A. Ramteke | Aniket S. Askar "Design Smart Energy Meter to Prevention of Power Theft and Automatic Billing" Published in International Journal of Trend in Scientific Research and Development (ijtsrd), ISSN: 2456-6470, Volume-6 | Issue-3, April 2022, pp.1581-1585, URL: www.ijtsrd.com/papers/ijtsrd49761.pdf



Copyright © 2022 by author (s) and International Journal of Trend in Scientific Research and Development Journal. This is an Open Access article distributed under the terms of the Creative Commons Attribution License (CC BY 4.0) (<http://creativecommons.org/licenses/by/4.0>)



remote monitoring and control of the domestic smart energy meter.

PROBLEM STATEMENT

There are many types of power theft ranging from rural areas and industries which causes huge amount in losses of power and some of these power theft ways as follows:

Power Tapping

The power theft is occurring in transmission line by illegal tapping of the lines to divert the way of power interrupted to the required destinations.

Meter Fraud

Meter tampering is an act which causes the meter runs slower or not at all and is basically theft of electricity from the company the supplies power. There are multiple ways to tampering with an electricity meter and some of they include turning the watt-hour meter upside down, replacing the meter is

such as a copper wire or knives, or drilling hole in Meter and inserting remove internal moving disk.

Payment Collection

People can pay billing by standing long rows in MSEB office and other the billing printing and distributed bill to the consumer.

Energy Theft

Energy theft is the big problem mostly in rural area because most of the people can theft from energy meter and the power supply authorities do not know when or where exact location are energy is theft occurred.

POWER THEFT PREVENTION USING SMART ENERGY METER

By tapping transmission line & meter tampering, the power theft can be reduced to for extent by wing the advanced smart meter. These smart meters can handle higher loads which are transferred by sub power station many times in the day time & while. Maintaining voltage 220 v/-240 V access the appliances.

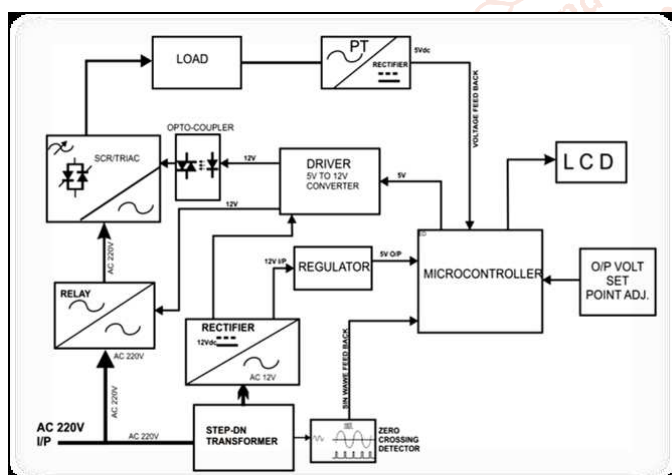

Fig.1 Block Diagram of SEM

CONSTRUCTION OF BLOCK DIAGRAM

The block diagram shows that. The main aim is to control the village and to keep balance the voltage across the load. With the help of ADC (analog to digital converter), which is present inside the Microcontroller, controller. Checks the incoming voltage coming from line. To control a +ve and the -ve half cycle of incoming AC firing angle control method is used. Monitoring every +ve /-ve half cycle is necessary to control a firing angle of any AC voltage Therefore to inform a controlled about start point of every cycle. A sine Wave Cycle Monitor (Zero crossing detectors) block is used in our project. When the controller knows the voltage across the load and signals frond the sine wave cycle monitor. Then the controller can calculate the firing angle and it also gives the firing angle to the AC -to A.C converter in which a static switch is used which is formed by a

SCR/TRIAC. As compared to the mechanical switches like relay, Static switch can be operated on high voltage and on high frequencies. The AC-to-AC converter output is then given to the load. Controller measures the voltage across the load with the help of potential Transformer (PT). As the microcontroller is able to read a voltage up to 5V dc only. The potential transformer is used to step down the voltage across the load to be measure & rectified to D.C. In our project, the Relay is used for tripping the input voltage in case of very high voltage and low voltage, which is beyond controllable limits. This relay is of 12 volts and the controller can give maximum of 5V, hence it is important to amplify the 5V to 12V, for which a Drive Circuit is used. The 5V DC is required for the microcontroller to work. The same will be generated by the Power which involves a step-down the transformer, rectifier, filter and regulator. The transformer step-down 220 V AC to 12V AC, then the rectifier and the filter converts this 12V AC to 12 V DC and finally the regulator converts the 12 v DC to a constant of 5V DC. This is how the smart meter keeps constant voltage across the loads and it also protects them from being damage by incoming higher voltage of transmission line.

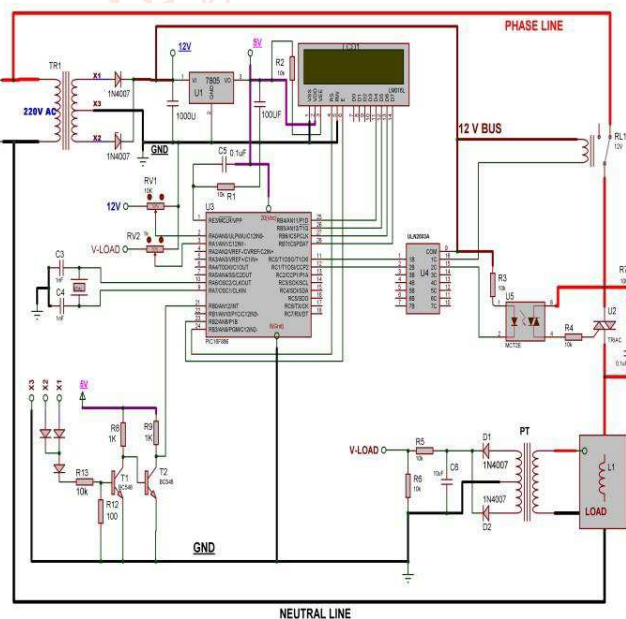

Fig.2 Circuit Diagram of SEM

WORKING OF SMART ENERGY METER

The step-down transformer of 220 v/12 v ac is used. Then the rectifier & the diode converted the 12 V ac to the 12 v DC. For the purity of de voltage Filter capacitor is used. The 12vdc is converted to the 5V DC by the regulator IC. This 5V DC is used by all the components. A capacitor on 5V DC is used as storage capacitor Microcontroller starts to operate and to reset the microcontroller; we used one capacitor & resistance. Microcontroller can measure the input as well as the output voltage, but here only output

voltage is measured so that we used here potential transformer. Rating of potential transformer 220/6v. This measures the voltage across the lead. This PT has 6v AC output. The filter and the rectifier are used to convert 6v ac to 6v dc. Microcontroller operates only on 5V constant therefore 6V dc cannot be given to the microcontroller directly. Therefore, the potential divider is used which reduces the 6V into 5V Controller identifies the output voltage & hence it generates the firing angle. The Firing angle turns on the relay and with the help of microcontroller, it gives signal to opto-coupler. The opto-coupler helps to TRIAC turns ON and then it continues with the load. The relay gets trip, if the voltage suddenly Increases or decreases. This is electromagnetic switch.

FUNCTION OF VARIOUS COMPONENTS OF SMART ENERGY METER

Functions of Inbuilt components of the smart meter are as follows:

Full Wave Rectifier (12v Ac to 12v Dc)

A Full Wave Rectifier is a circuit, which converts an ac voltage into a pulsating dc voltage using both half cycles of the applied ac voltage. It uses two diodes of which one conducts during one half cycle while the other conducts during the other half cycle of the applied.

Voltage Regulator (12v Dc to 12v Dc)

A voltage regulator is designed to automatically maintain a constant voltage level, where they stabilize the DC voltages used by the processor and other elements.

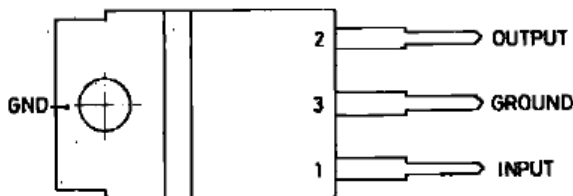
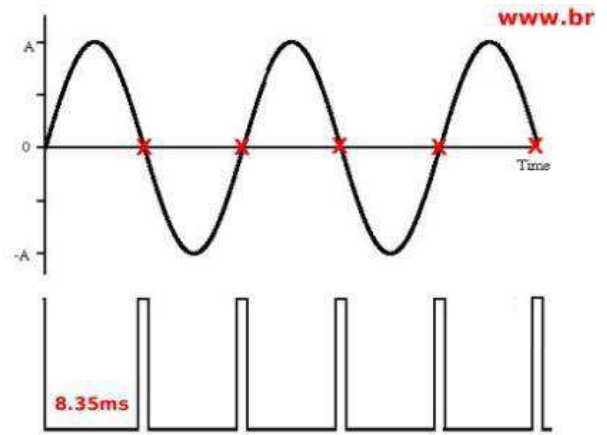

Fig.3.voltage Regulator

Zero Crossing Detectors

A zero-crossing detector is a one type of voltage comparator, used to detect a sine waveform transition from positive and negative, that coincides when the I/p crosses the zero -voltage condition. In alternating current, the zero crossing is the instantaneous point at which there is no voltage present. In a sine wave or other simple waveform, this normally occurs twice during each cycle. The pulse occurs at 0, 180, and 360 degrees. Regulated 5V is also used as biasing voltage for both transistors (Q1 and Q2) and the control section. A pulsating DC voltage is applied to the base of transistor Q1 through diode D3 and resistors R4 and R5. When the pulsating voltage goes to zero, the collector of transistor Q1 goes high. This is used for detecting the pulse when the voltage is

zero. Finally, the detected pulse from „OUTPUT“ is fed to the microcontroller of the control section.



Zero crossing pulse at 0, 180, and 360 degrees.

Fig.4 Zero Crossing Detector

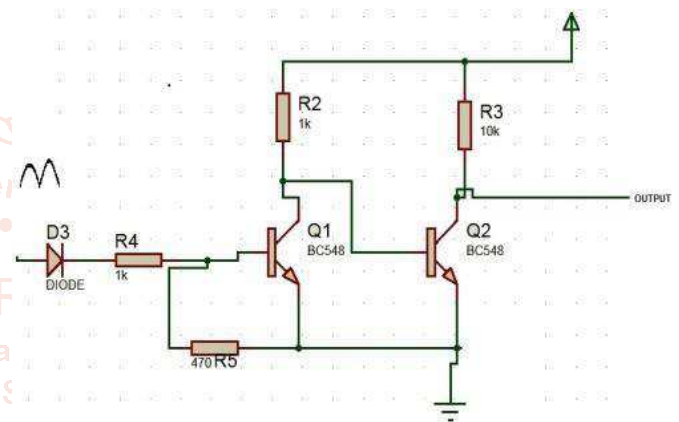

Fig.5

Driver

A Microcontroller digital logic output pin supplies only 10mA of current. External devices such as high-power relays can require >100mA and they need more voltages. In order to control such devices which, use high DC current, a transistor- based driver circuit is used to amplify current to the required levels. If the voltage and current levels are in perfect range, the transistor acts like a high-current switch controlled by the lower current digital logic signal.

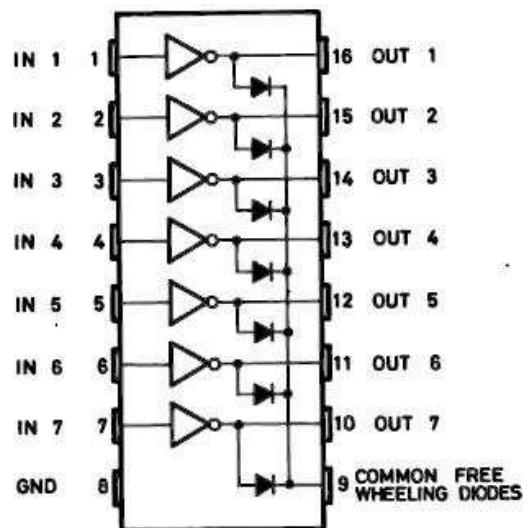

Fig.6 ULN2003 (driver)

OPTO-COUPLER

An opto-coupler are designed to provide complete electrical isolation between an input low voltage side (controller side) and output high voltage side (SCR/TRIAC side) circuits.

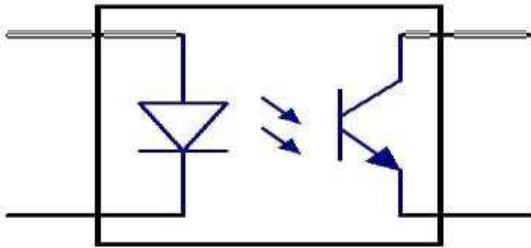

Fig.7 Symbol of Opto-coupler

LCD

LCD (Liquid Crystal Display) screen is an electronic display module and find a wide range of applications. A 16x2 LCD means it can display 16 characters per line and there are 2 such lines. In this LCD each character is displayed in 5x7 pixel matrix. This LCD

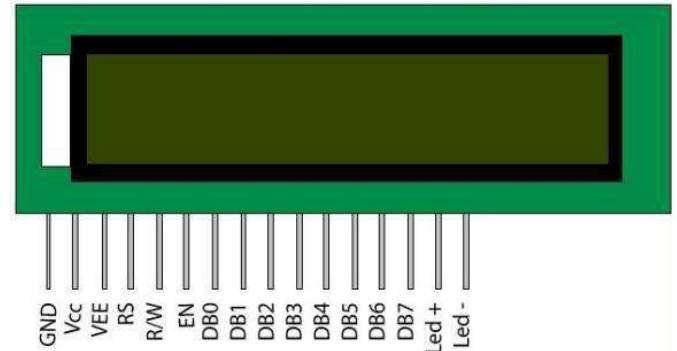

Fig.8 LCD

Pin no.	Function	Name
1.	Ground (0v)	Ground
2.	Supply voltage:5V (4.7V-5.3V)	Vcc
3.	Contrast adjustment: Through variable resistor	VEE
4.	Selects command resistor when low; and data resistor when high	Resistor select
5.	Low to write to the resistor; High to read from the resistor	Read/Write
6.	Send data to data pins when high to low pulse is given	Enable
7 to 14	8 Bit Data Pins	DB0 to DB7
15.	Backlight Vcc (5V)	Led +
16.	Backlight ground (0V)	Led-

Fig.9 Table of LCD pins with functions

Thyristor / TRIAC

These are Static devices used to switch. Static device is a kind of device which converts one type of energy or energy level in to another type of energy or energy level respectively without physical movement.

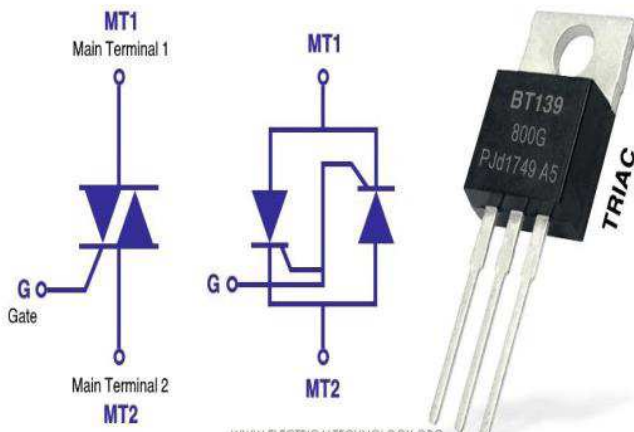

Fig.10 Triac/Transistor

Microcontroller

In our project we are using a PIC (16F886) microcontroller which has RISC (restricted Instruction Set Codes) architecture due to which

has two registers, namely, Command and Data. The command register stores the command instructions given to the LCD. A command is an instruction given to LCD to do a predefined task like initializing it, clearing its screen, setting the cursor position, controlling display etc. The data register stores the data to be displayed on the LCD. The data is the ASCII value of the character to be displayed on the LCD.

controller requires only One Clock Cycle to complete a single execution. In our project we are using a 28-pin microcontroller having 16K/b of FLASH ROM, 1.2K/b of RAM, and 256 bytes of EEPROM. This controller having an inbuilt 10 Bit ADC which requires measuring input and outputting analog voltages. The operating cycle of PIC(16F886) microcontroller is of 200n/s. The output port capability is off to deliver 5v/40mA on each portion.

POWER SUPPLY CIRCUIT

The all-electronic components require DC for their operation Therefore, the AC is stepped down. Then this AC is converted to DC supply by the rectification process. Some ripples may rectify unit is bypassed by connecting the capacitor in parallel. The 12v supply is given to LM7805 regulator now we need a regulated uninterrupted 5V DC supply, this involves production of 5V DC supply operate Microcontroller, require +5y de for whole circuit. By using step down Transformer, the supply voltage of 230v ac is stepped down to 12V. The in fed ac rectifying is converted to dc by using the rectifier unit. The rectifying unit involves bridge rectifiers which consists of diode for

rectification purpose Ripples coming out of the rectifying unit is by passed by connecting the capacitor in parallel. The output are further diminished by regulator for accurate +5v to the microcontroller circuit. For suppressing the ripples, the capacitor is connected in parallel.

METER TEMPERING PREVENTION METHOD

Meter temper prevents ill minded people from interfering with smart energy meter normal working. If anyone tried to interfere with the meter, the smart energy meter immediately gives tripping signal to the relay. Then relay tripped to the smart energy meter to cut-off condition and inform to the about it to the electricity power service authorities.

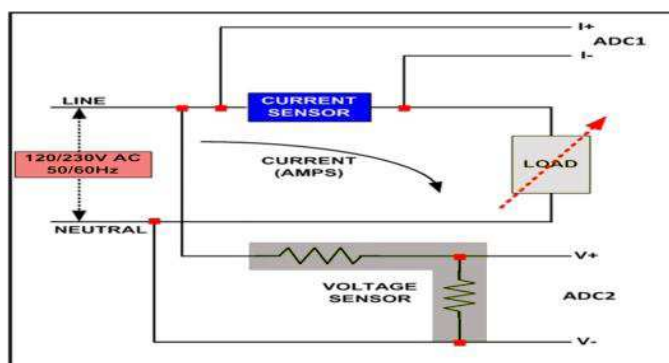

Fig.11 circuit for meter tempering prevention method

AUTOMATIC BILLING SYSTEM

This system enables the Electricity Department to read the meter reading automatically. This system consists of microcontroller unit. After recording the reading and this live meter reading are then sent to the electricity department on request. This system also disconnects the power supply to the residential services. For each smart energy meter, a dedicated RF trans receiver is required here we interface meter to

PC. This stores all the data and calculated exact billing amount and then sends it to microcontroller. This amount will show on LCD, if the consumer not pays the bill within stipulated time period, the power supply of the consumer will be disconnected automatically by the PC. In our project we are used in Visual Studio Software for automatic/digital billing system.

CONCLUSION

Power theft is prevented in the society but we by using and developing a power theft prevention and voltage stabilization devices like smart meter we can reduce it to far lower level. In our project device called smart meter has designed to meet these required of preventing power theft by hooking and by meter tempering and Automatic billing system has made smart meter a user friendly.

REFERANCE

- [1] Nikhil V. Patil, Rohan S. Kanase, Dnyaneshwar R. Bondar, P D Bamane, "Intelligent Energy Meter with Advanced Billing System and Electricity Theft Detection" IEEE-February-2017
- [2] Grzegorz Dudek, Anna Gawlak, Miros Karnataka, "Analysis of Smart Meter Data for Electricity Consumers." IEEE-April-2018
- [3] Visalatchi S, Kamal Sandeep K, "Smart Energy Metering and Power Theft Control using Arduino & GSM" IEEE-September-2017
- [4] Ashna K, Sudhish N. George, "GSM Based Automatic Energy Meter Reading System with Instant Billing" IEEE-October-2013