

# A Review on Power Flexibility, Generation and Distribution System

Rahul Gokhle<sup>1</sup>, Pramod Kumar Rathore<sup>2</sup>

<sup>1</sup>Student, <sup>2</sup>Assistant Professor,

<sup>1,2</sup>RKDF College of Engineering, Bhopal, Madhya Pradesh, India

## ABSTRACT

Distributed power generation is the latest field because of the ability to accommodate various types of Renewable/alternative energy sources, its hidden potential to improve the energy efficiency and power system capability, and its promise for power reliability and security. Many distributed energy sources exist such solar energy, fuel cell, micro turbine, and wind energy. Distributed power generation concept has been implemented in various places with various degree of complexity. A comprehensive review on the distributed power generation is presented in this paper.

**KEYWORDS:** *Distributed generation, renewable energy sources*

**How to cite this paper:** Rahul Gokhle | Pramod Kumar Rathore "A Review on Power Flexibility, Generation and Distribution System" Published in International Journal of Trend in Scientific Research and Development (ijtsrd), ISSN: 2456-6470, Volume-5 | Issue-6, October 2021, pp.77-83, URL: www.ijtsrd.com/papers/ijtsrd46379.pdf



IJTSRD46379

Copyright © 2021 by author (s) and International Journal of Trend in Scientific Research and Development Journal. This is an Open Access article distributed under the terms of the Creative Commons Attribution License (CC BY 4.0) (<http://creativecommons.org/licenses/by/4.0>)



## I. INTRODUCTION

Distributed Generation (DG), when fully implemented, can provide reliable, high-quality, and low-cost electric power. As a modular electric power generation close to the end user, it offers savings in the cost of grid expansion and line losses. If connected to the power grid, the bi-directional transactions between the grid and the local generation result in grid capacity enhancement, virtually uninterrupted power supply, and optimum energy cost due to the availability of use/buy/sell options.

Distributed power is a concept that covers a wide spectrum of schemes used for local electric power generation from renewable and non-renewable sources of energy in an environmentally responsible way. Main schemes are mainly based on solar energy, wind energy, fuel cells, and micro turbine engines. Twenty years ago, almost all the electric power was generated at large central power stations; twenty years from now, a good part of this power it is expected to be generated by small power units that will be distributed throughout the service grid. Since such units are located close to the customer, they are expected to better meet the customer's needs. In parallel to the introduction of distributed generation,

the legislative framework for the electricity sector is undergoing major changes in many industrial countries. These changes are driven by a moving towards more liberalization in order to create a competitive market environment. Within this competitive environment, decentralized power generation has to compete with centralized power generation. It is, however, often argued that electricity market regulations for competitive electricity markets do not provide an equal treatment of centralized and distributed generation. In order to become more familiar with the concept of DG, its definitions in some different countries are given here for comparison. Swedish legislation gives special treatment to small generation capacity of up to 1500 kW. Under Swedish law, a wind farm with one hundred 1500 kW wind turbines is still considered DG, as the rating of each wind energy unit, and not the total wind farm rating, is relevant for the law. But for hydro units, in comparison, it is the total rating of the power station that is relevant. In the English and Welsh power market, DG plants with a capacity of less than 100 MW are not centrally dispatched and if the capacity is less than 50 MW, the

power output does not have to be traded via the wholesale market. In New Zealand, DG is often considered generation of up to 5 MW. According to new electricity market regulations, distribution network owners/operators use 5 MW as a guideline for determining whether approval should be sought by the distribution network owner/operator from the national grid operator for the generation to be connected to a distribution network. There is no special definition for DG in many countries, such as California and Norway. Different definitions of DG are, however, not only used within different electricity market regulations, but also in the relevant literature. To avoid confusion by different definitions, a general definition for distributed generation is suggested: "Distributed generation is an electric power source connected directly to the distribution network or on the customer side of the meter" [1]. In the following sections, different sources of the distributed generation will be introduced and the application of each of them will be discussed.

## II. FUEL CELL

Fuel Cells (FC) are electrochemical devices converting the chemical energy content of a fuel directly to electrical energy. Fuel cells should be supplied with the fuel to the anode and oxidant (e.g., air) to the cathode. They perform a conversion equivalent to the different stages of traditional extraction of energy in the form of combustion heat, conversion of heat energy to mechanical energy (as with a turbine), and finally turning the mechanical energy into electricity (as with a dynamo or a synchronous generator) in one shot. They combine the molecules of a fuel and oxidizer without burning, dispensing with some of the inefficiencies and pollution of traditional combustion. Their output is a dc voltage that can be converted to an ac voltage by using an inverter and used locally or fed to the network. A Fuel cell is potentially the most efficient and modern approach to electric power generation.

The efficiency of the conversion, i.e., the ratio of the electrical output to the heat content of the fuel, could be as high as 65-70%. In fact, its electrical efficiency could be greater than 70% in theory. The current technology has only been capable of reaching efficiencies of around 45%. Combined cycles are envisaged to bring the electrical efficiency of plants based on high temperature cells up to around 60% [2]. The different types are: polymer electrolyte membrane, phosphoric acid, molten carbonate, solid oxide, alkaline, direct methanol fuel cell and regenerative fuel cell [3].

## III. SOLAR ENERGY

Photovoltaic (PV) cells are devices that convert sunlight to electricity, bypassing thermodynamic cycles and mechanical generators: sunlight photons free electrons from common silicon generating e.f.m at the PV terminals. The phenomenon was first discovered in the 18th century and the early photovoltaic cells were developed at Bell Labs in 1950, primarily for space applications. Solar cells have proved to be cost effective. Other than space satellites, the photovoltaic cells are being used in rural health clinics for refrigeration, water pumps for irrigation and for small-scale power generation. Since the output power of the solar cell depends upon the insolation level, and also at a specific insolation level, the I-V characteristic of a solar cell is a nonlinear relationship, different methods have been developed to locate the maximum power point of the cell, i.e., the operating point at which maximum power can be obtained from the cells [4]. One drawback of photovoltaic generation systems is the large area that is required to produce a considerable amount of electrical energy. The other drawback is that on some days, the insolation level is not high enough to produce the expected energy. This lowers the reliability of the system [5]-[6]. Photovoltaic generation systems need to be connected to the grid that acts as a pool of energy that can be taken from or added to, depending on the insolation level and the level of local consumption. In stand-alone mode of operation, some type of energy storage, such as a battery or a super capacitor, This has to be used to store the extra energy in or to get the necessary energy from, when the local generation is not enough. Conventionally, a two-stage PV energy conversion system is employed to connect a PV array to an electrical power system. The first stage, i.e., the DC/DC converter is controlled so as to track the maximum power point of PV arrays, adjust the level of the voltage for the next stage, and transfer energy to the batteries and the inverter. The second stage, i.e., the inverter or DC/AC converter, is controlled to produce an output voltage of grid quality, in stand-alone mode, or an output current in phase with the utility grid voltage to transfer power to the grid at unity power factor, in grid-connected mode. As the DC/DC and DC/AC converters have independent architectures and control goals, the controllers are easy to design. Yet, the efficiency of the entire conversion system is compromised because of the large number of individual devices, i.e. the DC/DC converter, batteries and the DC/AC converter [6].

#### IV. WIND ENERGY

wind energy is another DG source, which can be converted to electrical energy. The speed of the wind can be quite variable. Besides, some areas are not windy enough to extract considerable amount of energy from the wind.

The renewable energy sources such as wind, solar, etc., play a major role as electrical and mechanical energy supplies, not by replacing the conventional energy sources but supplementing them. The world is faced with a range of environmental issues that threaten ecosystems, health, economy and way of life. With increased public awareness of the role of the electricity sector in these matters, and the likely future customer choice in electricity and energy supply, industry will come under increasing expectations to reduce gas emissions. Preferred solutions to prevent emissions include energy and resources conservation as well as renewable and cleaner energy sources. The issue of global climate change is a result of fossil fuel combustion. In such an altered environment for the selection of new power plants, public attitudes will become much more important than they have been in the past. The public would like to protect the environment and, in particular, takes care of the environmental problems related to human life, such as air pollution. Also, the population strongly prefers using a combination of efficiency and renewable to meet energy needs [7]. Public polling information from United Kingdom shows that wind energy primary positive points are its environmentally friendly, renewable, and safe nature, as well as the fact that it helps to conserve fossil fuels. Surveys show that WG principal weaknesses are in that wind is intermittent and such a kind of electric power is more expensive than fossil-fired power.

Somebody a wares for their acoustic noise. The public support for wind has strengthened after wind plants were installed and operated for some time. In Alberta, Canada, a small 10MW wind power plant prevents the emission of nearly 23 billion kg/year of sulphur oxides, nitrogen oxides, and carbon dioxide, that would otherwise be produced by conventional power plants [7]. Due to the variations in the wind speed, most of the wind energy schemes are based on induction generators, as there is no stiff link between the rotational speed and the output frequency in this kind of machine. Besides, the reactive power source at the induction machines terminals plays a role to determine the output frequency [8]. Wind energy-based DG can be operated in either grid connected or stand-alone mode. Reference [8] proposes the scheme shown in Fig. 1, using a wind turbine as a grid

connected power source. The real power can be changed by adapting the blade pitch angle, whereas the reactive power is changed by the reactive power source at the terminals of the induction machine. In this figure, IG and SVC stand for induction generator and Static Var Compensator, respectively.

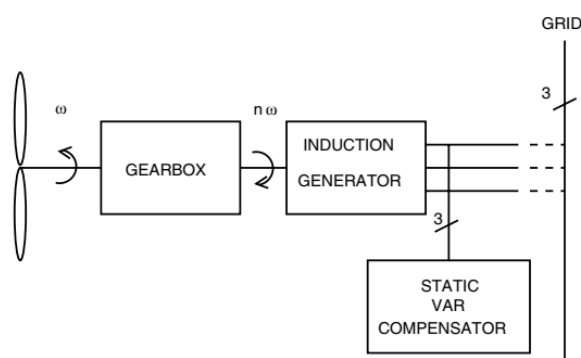

**Fig 1 Wind turbine-based distributed generation scheme**

Researchers have come up with different methods to track this maximum point to utilize the wind energy most efficiently. A major problem with windmill technology is in finding the control technique that enables tracking of the maximum point and extracting the largest possible amount of energy from the wind [9]-[11]. Another problem is that the turbine cannot rotate beyond a specific speed. Due to the above advantages of wind energy, today's wind industry at 2.5 billion dollars a year, represents a global business for which countries should prepare good strategies towards integrating wind power in increasingly competitive electricity markets. Unfortunately, just in a few countries, there is a solid market for wind industry and most countries do not have a political or economic base for this kind of industry. To date, over 80% of the global wind capacity is installed in Germany, USA, Denmark, and Spain, where the electricity feed laws have been introduced to stimulate a market for renewable energy sources.

These laws are characterized by their system of premium prices which have proved supportive of wind power. However, it is not easy to integrate wind energy into electricity markets which are traditionally based on large suppliers of thermal plants. Wind power meets some barriers when it is compared economically with traditional power sources. In this respect, it is important to mention the following points:

- wind has the disadvantage of being intermittent which raises questions about grid access and costs
- in best cases, wind plants have ranged from 1MW to 30 MW in size, while combined-cycle gas turbine power plants (the current industry favorite) have a capacity between 50 and 500 MW.

The current generation of wind turbines only has a few years or less of operation. This leads to the question on reliability and, indirectly, makes investment risky.

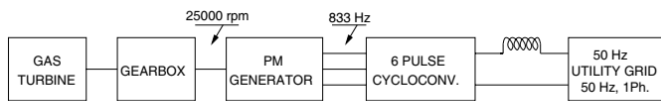

**Fig 2 the scheme proposed by [12]**

## V. MICROTURBINE-BASED ENERGY

There are some distributed power schemes based on the micro turbines as the prime mover for the generator. In these schemes the generator connected to the micro turbine is asynchronous machine whose output voltage has a frequency directly proportional to the angular speed of the micro turbines shaft. It has been proven that using a micro turbine- based power generation in parallel with the utility grid can effectively improve the reliability and minimize peak loads, and also may eliminate the need for reserve margin (standby) and may or may not sell back excess generation [12]. The prime mover of the generators in the above schemes can also be a diesel engine. Reference [11] suggests a combination of diesel engine and permanent magnet generator. This scheme has been designed to work in stand-alone mode. Since the diesel engine is not operating at a very high speed, the output frequency does not need to be changed and the output voltage can be directly applied to the load. In order to keep the voltage of the generator terminals constant a reactive power compensator has been placed across the terminals of the machine. One of the schemes that has been used before, includes a turbine or high-speed engine, as the prime mover, and a gearbox to reduce the output speed and regulate it so that the output frequency of the synchronous machine is equal to the grid frequency. In this scheme the gearbox is a mechanical component and mechanical systems show longer time response compared to electrical systems. Besides, the system will be lossy, heavy, and bulky. Reference [12] suggests a system using a cycloconverter to convert the frequency. The block diagram is shown in Fig. 2. A 6-pulse non-circulating current cycloconverter (833 Hz to 50 Hz) is used as the frequency changer for a high frequency permanent magnet generator. This generator-converter unit is driven by a high-efficiency, high-speed gas turbine in the power range of 250 kW to 870 kW. This system is intended for use in total energy systems or hybrid systems in vehicles and high-speed vessels.

If a high-speed gas turbine (75000 rpm) is used, low-volume and high efficiency power generation results.

However, a high ratio gearbox is required to adjust the turbine speed to the generator speed which is dictated by the grid frequency. This scheme cannot attain a high efficiency due to the presence of gearbox and unavoidable mechanical losses.

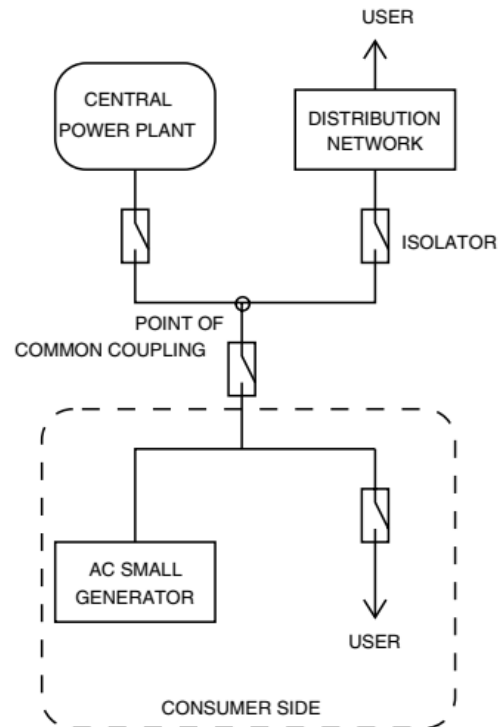

**Fig 3 Demand side DG configurations with utility services**

## VI. DGS OPPORTUNITIES AND CHALLENGES

### Opportunities

given the potential and probable application of interconnecting the dispersed DG “stand-by generating systems”, generating capabilities provide several benefits to both utility and consumers. The consumer will have consumption choices; they can reduce their energy expenditures by incorporating DGs that are powered by cheaper fuel sources, for example, the use of methane gas fueled turbine-generating units. Methane gas can be produced in a nearby landfill. Heat can also be produced through the burning of waste in incinerators; otherwise it will be produced using electricity. Using local or nearby fuel sources that could be generated from large amounts of municipal waste that otherwise need vast landfill sites adds to cities’ energy supply chain. As for the utility, it can use the DG power to enforce its distribution network voltage stability, as well as to increase its speaking capacity without suffering financial costs. Fig. 3 shows a typical demand-side DG system that is configured to supply both the consuming side as well as feeding the utility during the peak demand period or as a coordinated power quality system enhancement. By allowing consumers’ own DG units to provide electricity

during high electricity rate and short-term supply interruptions, continuous productivity is ensured and the reliability and power quality of the consumed electricity is increased. DG owners or operators could also receive a new source of revenue from electricity sales to the hosting electricity provider. Employing renewable energy sources on a large scale will have a positive impact. For instance, solar power stations are non-polluting and can provide electricity economically in suitable locations. In many large cities, photovoltaic units are incorporated into new buildings, either on the roof or in the cladding, and supply up to 30 percent of the household demand for electricity.

### Challenges

For successful integration of DG with Utilities, clear interconnection requirements must be formulated. A broad range of industry representatives have been participating in the development of a new standard for DG/Utility interconnection. An example of these activity is the undergoing IEEE standard P1547, which is meant to provide a uniform standard for interconnection of distributed resources with electric power systems. Since the introduction of DG provides an unwanted source for re-distribution of both load and fault current, as well as possible source of over voltage and islanded operation [13], the investigated requirements are looking at issues such as performance, operation, testing, safety and maintenance of the interconnection. The current engineering practice for DG/Utility interconnected systems is to revert the utility systems to its original configuration (radial or meshed distribution system) with all interconnected DG units de-energized whenever an unexpected disturbance occurs in the system. Since most distribution systems comprise radial feeders, this practice leads to the discontinuation of the supply for all the downstream customers. Thus, the system reliability stays at the same level as it was before integrating the DG with the system [14]-[16]. At the same time, there exist in the system some unsupplied loads and unutilized DG capacity. If interconnected DGs are permitted to supply loads during utility outages, the system reliability will be much better and the customers will not experience any discontinuity of their supply. This goal can be achieved by simply coordinating intention islanding of DG units [17].

## VII. DISTRIBUTED GENERATION ATTRIBUTES

For successful matching of the renewable energy sources as the prime fuel and distributed generation, it is worthwhile looking at the sources attributes and measure how the system will be apply to meet the

continuous rise in electricity demand. DG fuelled by RES is emerging technologies using continuously replenished energy sources. Various sized of DG systems are increasingly being adopted and integrated in various countries to meet the increasing demand for heat and electricity. Electricity from RES has proved to be viable, and can meet up to 20 percent of electricity needs, in the case of wind energy in Germany and Denmark [18]. A schematic diagram illustrating the main components of a grid tie wind energy generation system is shown in Fig. 4. Here, the wind power is converted into mechanical power that drives the generator. For utility integration, the generator system requires an electronic regulator to control the electrical voltage output, as it varies with the wind intensity, to the level and standards for integration with the existing utility network voltage. Energy attributes address the investment as well as the sustainability issues for providing electricity. It is difficult to merge RES without defining their attributes against well known sources such as coal. The National Renewable Energy Laboratory, NREL, defines the attributes listed below. NREL is the principal research laboratory for the Department of Energy (DOE) Office of Energy Efficiency and Renewable Energy in the USA. Some of the listed attributes are quantitative

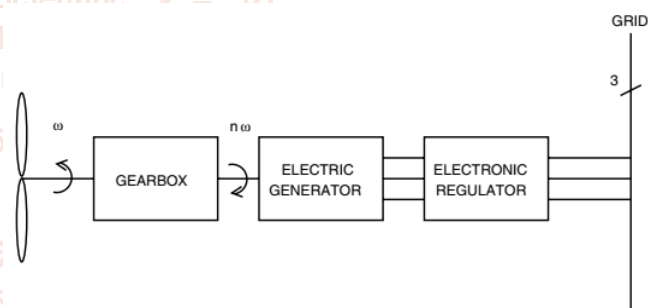

Fig 4 Main stages of integrating wind energy renewable source for power generation in nature, such as capability, capacity and cost, while others can only be considered in a qualitative way, such as indirect benefits and risk diversity. The attributes are:

- **Capability:** A measure of the capability of the power plant to deliver its designed full load capacity in a given period under normal conditions.
- **Availability:** A measure of how long power will be available. Routine maintenance, unplanned maintenance (i.e., breakdowns), refueling, and modifications are prime causes of unavailability in conventional power sources.
- **Dispatch ability:** A measure of the degree of control that the power plant/utility could exercise over the hour-by hour and minute-by-minute system output.

- Modularity: Modularity has implications for installation, increased capacity, availability, and capital investment risk. Using modular generating units allows expansion, when it is required, by adding more units of the same design and size.
- Location: Some power plants are built very close to the energy source, which is not necessarily the optimal location for consumers.
- Cost: Refers to the cost of capital investment, operation and management, and costs incurred or avoided as the result of employing a technology.
- Incentives: The subsidies provided by the government to promote the development of a technology.
- External costs and indirect benefits: The costs and benefits, theoretically borne by others, of operating a technology for which the others receive no compensation or make no payment. For example, there are many property owners who have installed solar thermal and photovoltaic (PV) systems on their property. The installed PV system is in many cases supplying almost 30% of the required energy to that household, which otherwise would be provided by centralized power plants through the grid. The benefits are shared, but not the costs, which are borne directly by the owner and indirectly by the provider. The provider is relieved from his commitment to increasing capacity and the related financial burden.

These external factors may also include environmental and regional economic impacts.

- Risk diversity: Risk describes any unanticipated, unfavourable condition, including unpredicted availability problems with a technology, adverse changes in market conditions, and unexpected changes in legislation.

## VIII. CONCLUSION

In this paper, a short introduction about all different sources of distributed generation was given. Fuel Cell, Solar Energy, Wind Energy, Micro turbine were named as the main sources for distributed generation. Each one was discussed and briefly compared to each other. It is worth noting that most sources available for DG are renewable. The use of different technology depends on several factors including plant location and system specification; somewhere a combination of them is a good choice. It is expected that in the future a good part of the electrical energy will come from DG. A more detailed discussion about these different sources will be given in the following papers.

## REFERENCES

- [1] T. Ackermann, G. Andersson, L. Soder, "Electricity Market Regulations and their Impact on Distributed Generation", *Proc. of Int. Conf. on Electric Utility Deregulation and Power Technologies*, 2000, pp. 608-613.
- [2] J. Padullas, G. W. Ault, J. R. McDonald, "An Approach to the Dynamic Modelling of Fuel Cell Characteristics For Distributed Generation Operation", *IEEE Power Engineering Society Winter Meeting 2000*, Vol. 1, 2000, pp. 134-138.
- [3] <http://216.51.18.233/fctypes.htm>, *Fuel Cells 2000*, March 2002.
- [4] T. Kim, Ho-GyunAhn, S. Park, "A Novel Maximum Power Point Tracking Control For Photovoltaic Power System Under Rapidly Changing Solar Radiation", *Proc. of IEEE-ISIE 2001*, 2001.
- [5] R. Billinton, "Capacity Expansion of Small Isolated Power Systems Using PV and Wind Energy", *IEEE Trans. on Power systems*, Vol. 16, No. 4, November 2001, pp. 892-897.
- [6] T. J. Liang, Y. C. Kuo and J. F. Chen, "Single Stage Photovoltaic Energy Conversion System, Electrical Power Applications", *IEE Proceedings*, Vol.: 148, Issue 4, July 2001.
- [7] L. Surugiu, I. Paraschivoiu, "Environmental, Social and Economic Aspects of Wind Energy", *Energy Conversion Engineering Conference and Exhibit, 2000 (IECE)*, 2000, pp. 1167-1174.
- [8] E. S. Abdin, W. Xu, "Control Design and Dynamic Performance Analysis of a Wind Turbine-Induction Generator Unit", *IEEE Trans. on Energy Conversion*, Vol. 15, No. 1, March 2000, pp. 91-96.
- [9] M. Komatsu, H. Miyamoto, H. Ohmori and A. Sano, "Output Maximization Control of Wind Turbine Based on Extremum Control Strategy", *Proceedings of the American Control Conference*, 2001, pp. 1739-1740.
- [10] M. W. Davis, A. H. Gifford, T. J. Krupa, "Micro turbines- An Economic and Reliability Evaluation for Commercial, Residential, and Remote Load Applications", Vol. 14, No. 4, November 1999.
- [11] M. A. Rahman, A. M. Oshieba, T. S. Radwan, E. S. Abdin, "Modelling and Controller Design of An Isolated Diesel Engine Permanent

- Magnet Synchronous Generator”, *IEEE Trans. on Energy Conversion*, Vol. 11, No. 2, June 1996, pp.
- [12] N. H. M. Hofmeester, P. P. J. van den Bosch, “High frequency Cycloconverter Control”, PESC’94 Record, 1994, pp. 1071-1076.
- [13] K. A. Nigim, and Y. Hegazy, “Intention Islanding of Distributed Generation for Reliability Enhancement”, IEEE- PES Annual Meeting, 2003, p. 2451.
- [14] P. Barker, “Determining the Impact of Distributed Generation on Power Systems: part 1- Radial Distribution Systems”, IEEE, 2000, pp. 16451656.
- [15] R. C. Dugan, and S. K. Price, “Issues for Distributed Generation in the US”, IEEE Power Engineering Society Winter Meeting, vol. 1, 2002, pp. 121- 126.
- [16] L. A. Kojovic and R. Willoughby, “Integration of Distributed Generation in a Typical USA Distribution System”, IEE- CIRED 2001 Conf. Rec., conference publication No. 482, 2001, pp. 18-21.
- [17] N. R. Friedman, “Distributed Energy Resources Interconnection Systems: Technology Review and Research Needs”, National Renewable Energy Laboratory, report SR-560-32459, 2002.
- [18] Global Wind Energy Council (GWEC), “Global Wind Power Continues Expansion”, Press Release, Brussels, March 2005.

