

Optimization Technique for Power Quality Improvement using DSTATCOM (Neural Network Approach) – A Review

Hareram Mishra¹, Manju Gupta², Dr. Anuprita Mishra³

¹Student, ²Associate Professor, ³Professor,

^{1,2}Oriental Institute of Science & Technology, Bhopal, Madhya Pradesh, India

ABSTRACT

As the power demand has been increasing rapidly, power generation and transmission are being affected due to limited resources, environmental restrictions and other losses. soft computing the techniques of correcting the supply voltage sag, swell and interruption in a distributed system. At present, a wide range of very flexible controllers, which capitalize on newly available power electronics components, are emerging for custom power applications. Power electronic-based equipment aimed at enhancing the reliability and quality of power flows in low voltage distribution networks. A control algorithm is used for the extraction of the fundamental weighted value of active and reactive power components. Using digital signal processor the DSTATCOM is developed and its performance of DSTATCOM is found to be satisfactory for various types of loads.

KEYWORDS: D-Statcom, DVR, Voltage Dips, Swells, Power Quality

How to cite this paper: Hareram Mishra | Manju Gupta | Dr. Anuprita Mishra "Optimization Technique for Power Quality Improvement using DSTATCOM (Neural Network Approach) – A Review" Published in International Journal of Trend in Scientific Research and Development (ijtsrd), ISSN: 2456-6470, Volume-5 | Issue-5, August 2021, pp.1828-1832, URL: www.ijtsrd.com/papers/ijtsrd45219.pdf



Copyright © 2021 by author (s) and International Journal of Trend in Scientific Research and Development Journal. This is an Open Access article distributed under the terms of the Creative Commons Attribution License (CC BY 4.0) (<http://creativecommons.org/licenses/by/4.0>)



I. INTRODUCTION

As the power demand has been increasing rapidly, power generation and transmission are being affected due to limited resources, environmental restrictions and other losses. The quality of available supply power has a direct economic impact on industrial and domestic sectors which affects the growth of any nation. This issue is more serious in electronic based systems. The level of harmonics and reactive power demand are popular parameters that specify the degree of distortion and reactive power demand at a particular bus of the utility.

This implies that some measures must be taken in order to achieve higher levels of Power Quality. The FACTS devices and Custom power devices are introduced to electrical system to improve the power quality of the electrical power. DVR, STATCOM/DSTATCOM, ACTIVE FILTERS, UPFC, UPQC etc are some of the devices used to improve the power quality of the voltage and current.

With the help of these devices, we are capable to reduce the problems related to power quality. Under the thesis work among the different custom power devices DSTATCOM has been used to improve the quality of power under different conditions.

The power system, the major power quality problems are poor load power factor, harmonic contents in loads, notching in load voltages, DC offset on load voltages, unbalanced loads, supply voltage distortion, voltage sag, & voltage swell. One of the most common power quality problems today is voltage sag. Voltage sag is a short time event during which a reduction in R.M.S. voltage magnitude occurs. It is often set only by two parameters, depth/magnitude and duration. The voltage dip magnitude is ranged from 10-90% of nominal voltage (which corresponds to 90-10% remaining voltage) and with a duration from half a cycle to 1 minute. In a three-phase system, the voltage sag is by nature a three-phase

phenomenon which affects both the phase-to-ground and phase-to-phase voltages. The faults are single-phase or multiple-phase short-circuit, which leads to high currents[1].

The introduction of FACTS has given the new direction to the power system to solve the power quality problems. At present, a wide range of very flexible controllers are emerging for custom power applications. The FACTS controllers like SVC, TCSC, TCPST, STATCOM, SSSC, UPFC, etc. are mainly used controllers. Among these, the STATCOM is the most effective device. The STATCOM is a shunt device & based on VSC principle. The inverter circuit along with interface transformers/inductors is called a STATCOM.

II. VOLTAGE SOURCE CONVERTER (VSC) and CUSTOM POWER DEVICES

A voltage-source converter is a power electronic device, which can generate a sinusoidal voltage with any required magnitude, frequency and phase angle. The VSC is used to either completely replace the voltage or to inject the 'Dip voltage'. The 'Dip voltage' is the difference between the nominal voltage and the actual. The converter is normally based on some kind of energy storage i.e. capacitor, which will supply the converter with a DC voltage. The solid-state electronics in the converter is then switched to get the desired output voltage. Normally the VSC is not only used for voltage dip mitigation, but also for other power quality issues, e.g. flicker and harmonics.

A. Shunt voltage controller [Distribution Static Compensator (DSTATCOM)]

The D-STATCOM (Distribution Static Compensator) configuration consists of a VSC, a DC energy storage device; a coupling transformer connected in shunt with the ac system, and associated control circuits. Fig. 1,

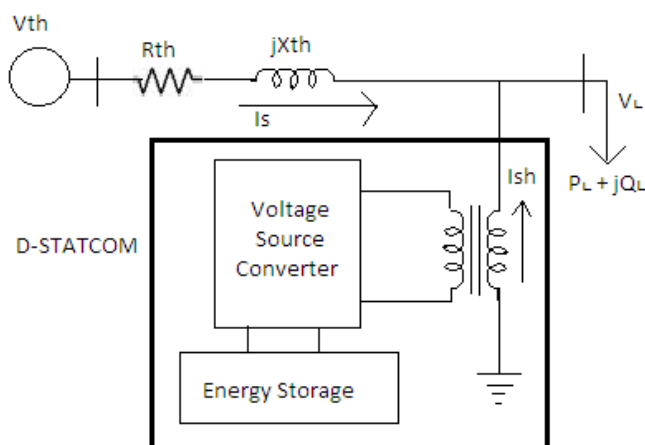

Figure 1 Schematic Dig of D-STATCOM

Shows the basic configuration of D-STATCOM. Here, such device is employed to provide continuous voltage regulation using an indirectly controlled converter. Suitable adjustment of the phase and magnitude of the D-STATCOM output voltages allows effective control of active and reactive power exchanges between the D-STATCOM and the AC system.

The VSC connected in shunt with the AC system provides a multifunctional topology which can be used for up to three quite distinct purposes:

- Voltage regulation and compensation of reactive power
- Correction of power factor
- Elimination of current harmonics.

Figure 1 shows the shunt injected current I_{sh} corrects the voltage sag by adjusting the voltage drop across the system impedance Z_{th} . The value of I_{sh} can be controlled by adjusting the output voltage of the converter.

$$I_{sh} = I_L - I_s$$

It is mentioned that the effectiveness of the STATCOM in correcting voltage sag depends on the value of Z_{th} or fault level of the load bus. When the shunt injected current I_{sh} is kept in quadrature with V_L the desired voltage correction can be achieved without injecting any active power into the system. On the other hand, when the value of I_{sh} is minimized, the same voltage correction can be achieved with minimum apparent power injection into the system.

B. Dynamic voltage restorer / regulator (DVR)

The Dynamic Voltage Restorer (DVR) is a series connected device analogous to a SSSC. The main function of a DVR is to eliminate or reduce voltage sags seen by sensitive loads such as semiconductor manufacturing plant or IT industry.. They have been designed to compensate three phase voltage sags up to 35% for duration of time less than half a second (depending on the requirement). If the voltage sag occurs only in one phase (caused by SLG faults) then the DVR may be designed to provide compensation for sags exceeding 50%. A DVR is connected in series with the feeder using a transformer. The low voltage winding is connected to the converter. A DVR with IGBT/IGCT devices can be controlled to act as a series active filter to isolate the load from voltage harmonics on the source side. It is also possible to balance the voltage on the load side by injecting negative and/or zero sequence voltages in addition to harmonic voltages.

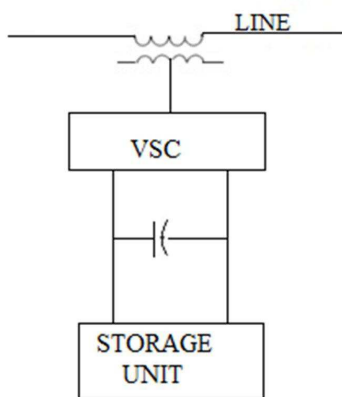

Figure 3: Basic configuration of DVR

C. UNIFIED POWER QUALITY CONDITIONER (UPQC)

Unified power quality conditioners are viable compensation devices that are used to ensure that delivered power meets all required standards and specifications at the point of installation.

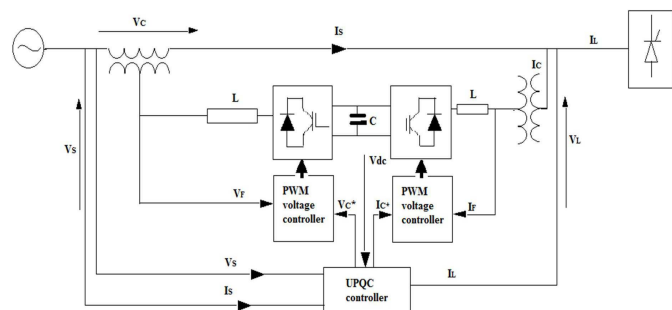

Figure 4: Basic Configuration of UPQC

The ideal UPQC can be represented as the combination of a voltage source converter (injecting shunt current) and a common DC link (connected to a DC capacitor).

UPQC consist of combined series active power filter that compensates voltage harmonics of the power supply, and shunt active power filter that compensates harmonic currents of a non-linear load. This dual functionality makes the UPQC as one of the most suitable devices that could solve the problems of both consumers as well as of utility. UPQC, thus can help to improve voltage profile and hence the overall health of power distribution system

III. SYSTEM CONFIGURATION AND CONTROL ALGORITHM AND PROPOSE WORK

The performance of any custom power device depends very much upon the control algorithm used for the reference current estimation and gating pulse generation scheme. An implementation of a three phase distribution static compensator (DSTATCOM) using a control algorithm for its functions under nonlinear loads such as load balancing and reactive power compensation for power factor, and zero voltage regulation. The main advantage of this method is that it requires only waveforms of voltages

and currents. A neural network with memory is used to identify the nonlinear load admittance. Once training is achieved, the neural network predicts the true harmonic current of the load when supplied with a clean sine wave. Feed forward back propagation (BP) artificial neural network (ANN) consists of various layers such as the input layer, hidden layer, and output layer. It is based on feed forward BP with a high ability to deal with complex nonlinear problems.

The BP control algorithm is also used to design the pattern classification model based on decision support system. The standard BP model has been used with the full connection of each node in the layers from input to the output layers. Some applications of this algorithm are as to the identification of user faces, industrial processes, data analysis, mapping data, control of power quality improvement devices, etc. The control of power quality devices by neural network is a latest research area in the field of power engineering. The extraction of harmonic components decides the performance of compensating devices. The BP algorithm which trained the sample can detect the signal of the power quality problem in real time. Its simulation study for harmonic detection is presented. The proposed control algorithm is used for harmonic suppression and load balancing in PFC and zero voltage regulation (ZVR) modes with dc voltage regulation of DSTATCOM. In this work, the proposed control algorithm on a DSTATCOM is implemented for the compensation of nonlinear loads.

A voltage source converter(VSC)-based DSTATCOM is connected to a three phase ac mains feeding three phase linear/nonlinear loads with internal grid impedance which is shown in Fig. 4

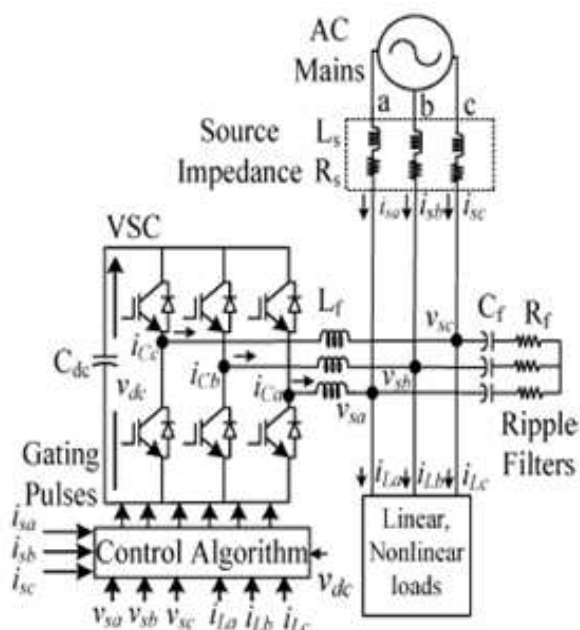

Figure 4 Schematic diagram of VSC-based DSTATCOM

The performance of DSTATCOM depends upon the accuracy of harmonic current detection. For reducing ripple in compensating currents, the tuned values of interfacing inductors (L_f) are connected at the ac output of the VSC. A three phase series combination of capacitor (C_f) and a resistor (R_f) represents the shunt passive ripple filter which is connected at a point of common coupling (PCC) for reducing the high frequency switching noise of the VSC. The DSTATCOM currents (i_{cabc}) are injected as required compensating currents to cancel the reactive power components and harmonics of the load currents so that loading due to reactive power component/harmonics is reduced on the distribution system. In this algorithm, the phase PCC voltages, source current (i_{sa}, i_{sb}, i_{sc}) and (i_{La}, i_{Lb}, i_{Lc}) and dc bus voltage (V_{dc}) are required for the extraction of reference source currents. There are two primary modes for the operation of this algorithm: The first one is a feed forward, and the second is the BP of error or supervised learning.

A **BP training** algorithm is used to estimate the three phase weighted value of load active power current components (W_{ap}, W_{bp}, W_{cp}) and reactive power current components (W_{aq}, W_{bq}, W_{cq}) from polluted load currents using the feed forward and supervised principle. In this estimation, the input layer for three phases (a, b, and c) is expressed as

The detail application of this algorithm for the estimation of various control parameters is given as follows.

$$I_{iap} = W_0 + i_{La}u_{ap} + i_{Lb}u_{bp} + i_{Lc}u_{cp} \quad (1)$$

$$I_{ibp} = W_0 + i_{La}u_{ap} + i_{Lb}u_{bp} + i_{Lc}u_{cp} \quad (2)$$

$$I_{icp} = W_0 + i_{La}u_{ap} + i_{Lb}u_{bp} + i_{Lc}u_{cp} \quad (3)$$

Where W_0 is the selected value of the initial weight and (u_{ap}, u_{bp}, u_{cp}) are the in-phase unit templates. In-phase unit templates are estimated using sensed PCC phase voltages (V_{sa}, V_{sb}, V_{sc}) It is the relation of the phase voltage and the amplitude of the PCC voltage (V_t). The amplitude of sensed PCC voltages is estimated as

$$V_t = \sqrt{2(v_{sa}^2 + v_{sb}^2 + v_{sc}^2)/3} \quad (4)$$

The in-phase unit templates of PCC voltages (u_{ap}, u_{bp}, u_{cp}) are estimated as

$$u_{ap} = \frac{v_{sa}}{v_t} \quad u_{bp} = \frac{v_{sb}}{v_t} \quad u_{cp} = \frac{v_{sc}}{v_t} \quad (5)$$

The extracted values of $I_{Lap}, I_{Lbp}, I_{Lcp}$ are passed through a sigmoid function as an activation function,

and the output signals Z_{ap}, Z_{bp}, Z_{cp} of the feedforward section are expressed as

$$z_{ap} = f(I_{iap}) \quad (6)$$

$$z_{bp} = f(I_{iap}) \quad (7)$$

$$z_{cp} = f(I_{iap}) \quad (8)$$

The estimated values of Z_{ap}, Z_{bp}, Z_{cp} are fed to a hidden layer as input signals. The three phase outputs of this layer $I_{Lap1}, I_{Lbp1}, I_{Lcp1}$ before the activation function are expressed as

$$I_{Lap1} = W_{01} + W_{ap}Z_{ap} + W_{bp}Z_{bp} + W_{cp}Z_{cp} \quad (9)$$

$$I_{Lap1} = W_{01} + W_{ap}Z_{ap} + W_{bp}Z_{bp} + W_{cp}Z_{cp} \quad (10)$$

$$I_{Lap1} = W_{01} + W_{ap}Z_{ap} + W_{bp}Z_{bp} + W_{cp}Z_{cp} \quad (11)$$

Where ($W_{01}, W_{ap}, W_{bp}, W_{cp}$) are the selected value of the initial weight in the hidden layer and the updated values of three phase weights using the average weighted value (W_p) of the active power current component as a feedback signal, respectively. The updated weight of phase “a” active power current components of load current “ W_{ap} ” at the n th sampling instant is expressed as

$$w_{ap} = w_p(n) + \mu \{w_p(n) - w_{ap1}(n)\} f'(I_{ap1}) z_{ap}(n)$$

where (n) and (n) are the average weighted value of the active power component of load currents and the updated weighted value of phase “a” at the n th sampling instant, respectively and $w_{ap1}(n)$ and $Z_{ap}(n)$ are the phase “a” fundamental weighted amplitude of the active power component of the load current and the output of the feed forward section of the algorithm at the n th instant, respectively. $f(I_{ap1})$ and μ are represented as the derivative of I_{ap1} components and the learning rate. Similarly, for phase “b” and phase “c,” the updated weighted values of the active power current components of the load current are also expressed as same. The extracted values of $I_{ap1}, I_{bp1},$ and I_{cp1} are passed through a sigmoid function as an activation function to the estimation of the fundamental active components in terms of three phase weights $w_{ap1}, w_{bp1},$ and w_{cp1} as

$$z_{ap1} = f(I_{Lap1}) \quad (13)$$

$$z_{bp1} = f(I_{Lap1}) \quad (14)$$

$$z_{cp1} = f(I_{Lap1}) \quad (15)$$

IV. CONCLUSION

Using this work, the investigation on the role of DSTATCOM is carried out to improve the power

quality in distribution networks with static linear and non-linear loads. PI controller is used with the device to enhance its performance. Test system is analyzed and results are presented in the previous chapter. DSTATCOM in the distribution networks under different fault conditions and it can be concluded that DSTATCOM effectively improves the power quality in distribution networks with static linear. A VSC-based DSTATCOM has been accepted as the most preferred solution for power quality improvement as PFC and to maintain rated PCC voltage. A three phase DSTATCOM has been implemented for the compensation of nonlinear loads us a BPT control algorithm to verify its effectiveness. The proposed BPT control algorithm has been used for the extraction of reference source currents to generate the switching pulses for IGBTs of the VSC of DSTATCOM.

V. REFERENCES

- [1] International Journal of Scientific and Research Publications, Volume 4, Issue 4, April 2014 ISSN 2250-3153.
- [2] Roger C. Dugan, Mark F. McGranaghan and H. Wayne Beaty, Electrical Power, Systems Quality, Tata Mc Graw- Hill. Pages 1-8 and 39-80.
- [3] Bhim Singh, Alka Adya, A.P. Mittal, J.R.P Gupta, "Power Quality Enhancement with DSTATCOM for Small Isolated Alternator feeding Distribution System", conference on Power Electronics and Drive Systems, vol.1, pp. 274-279, 2005.
- [4] Alexander Kusko, Sc.D., P.E., Marc T.Thompson, Ph.D., Power Quality in Electrical Systems, Tata Mc Graw-Hill publications, 2007.
- [5] H. Nasiraghdam and A. Jalilian, "Balanced and Unbalanced Voltage Sag Mitigation Using DSTATCOM with Linear and Nonlinear Loads", Conference on World Academy of Science, Engineering and Technology, pp. 20–25, 2007.
- [6] J. Sun, D. Czarkowski and Z. Zabar, "Voltage Flicker Mitigation Using PWM-Based Distribution STATCOM", Conference on Power Engineering Society Summer Meeting, Publication, vol.1 ,pp. 616 – 621,2002.
- [7] Sung-Min, Woo Dae-Wook Kang, Woo-Chol Lee and Dong-Seok Hyun, "The Distribution STATCOM for Reducing the Effect of Voltage Sag and Swell", Conference on IECON'01: The 27th Annual Conference of the IEEE Industrial Electronics Society Publication, vol.2, pp.1132 - 1137,2001.
- [8] M. G. Molina, P. E. Mercado, "Control Design and Simulation of DSTATCOM with Energy Storage for Power Quality Improvements", Conference on IEEE PES Transmission and Distribution Conference and Exposition Latin America, Venezuela, pp.1 - 7, 2006.
- [9] Pierre Giroux, Gilbert Sybille Hoang Le-Huy, "Modeling and Simulation of a Distribution STATCOM using Simulink's Power System Blockset", Conference on IECON 01: The 27th Annual Conference of the IEEE Industrial Electronics Society, vol. 2, pp. 990 – 99, 2001.
- [10] Afshin Lashkar Ara and Seyed Ali Nabavi Niaki, "Comparison of The Facts Equipment Operation in Transmission and Distribution Systems" Conference on 17th International Conference on Electricity Distribution Barcelona, vol.2, pp.44,2003.
- [11] Ben-Sheng Chen and Yuan-Yih Hsu, "An Analytical Approach to Harmonic Analysis and Controller Design of STATCOM", Conference on IEEE Transactions on Power Delivery, vol.22, 2007