

Design and Performance Analysis of a LCD Laboratory Lantern

Nwadike Emmanuel Chinagorom, Azaka Onyemazuwa Andrew

Department of Mechanical Engineering, Nnamdi Azikiwe University, Awka, Anambra State, Nigeria

ABSTRACT

This paper presents the performance of a LCD laboratory lantern designed to combust varieties of biofuels. The burner was designed as a laboratory scale standard model for experimental purposes. The effect of biofuel atomization on the temperature and structure of flame in the near-burner region of a multi-fuel stabilised burner of a laboratory scale lantern was investigated experimentally with the help of a microcontroller made of pic 16F877. The laboratory scale lantern is of two litres capacity and was designed and constructed at the department of Mechanical Engineering, Nnamdi Azikiwe University to be used for laboratory combustion analysis, such as flame stability, temperature, height etc with the help of microcontroller made of pic 16F877 which takes temperature reading between 0-150°C and content of flame in order to determine its structure. A 16 by 2 liquid crystal display was used to read out the values of the temperature read by the LM35. The LCD was interfaced to the microcontroller in a 4bit mode. The LM35 Temperature Sensor used in this design has Zero offset voltage, which means that the Output = 0V at 0 °C. The design of the fuel level detector unit was achieved using BC548 NPN transistor connected via collector to the microcontroller unit. The burner was designed to atomize and ignite a combination of gaseous, liquid and biofuels. Detailed fuel flow rate and flame temperature measurements were obtained by means of a regression model and a LM35 thermocouple. The measurements aim to provide additional understanding on the efficiency and combustion process interaction in laboratory scale burners which can lead to useful conclusions about the properties and structure of flames produced from different biofuels to ascertain their different areas of industrial applications.

How to cite this paper: Nwadike Emmanuel Chinagorom | Azaka Onyemazuwa Andrew "Design and Performance Analysis of a LCD Laboratory Lantern" Published in International Journal of Trend in Scientific Research and Development (ijtsrd), ISSN: 2456-6470, Volume-5 | Issue-3, April 2021, pp.953-959, URL: www.ijtsrd.com/papers/ijtsrd40033.pdf



IJTSRD40033

Copyright © 2021 by author (s) and International Journal of Trend in Scientific Research and Development Journal. This is an Open Access article distributed under the terms of the Creative Commons Attribution License (CC BY 4.0) (<http://creativecommons.org/licenses/by/4.0>)



KEYWORDS: Bio Lantern, Combustion, LCD, Microcontroller

1. INTRODUCTION

Combustion is the most important process in engineering, which involves turbulent fluid flow, heat transfer, chemical reactions, radioactive heat transfer and other complicated physical and chemical phenomena (Abbas et al, 1997). Typical engineering applications include internal combustion engines, power station combustors, boilers furnaces, biogas stoves, bio-lantern etc. It is important to study the different modes of combustion taking place in these instruments, chemical kinetics involved, temperature and flame velocity, mass flow rate of the fuel etc, to improvise the working of these equipment's and maximizing the efficiency.

The different modes of Combustion are premixed combustion, diffusion combustion and mixed mode combustion. In premixed combustion air and fuel are premixed to the required stoichiometry before burning. In the diffusion mode, a diffusion flame may be defined as a non-premixed, quasi steady, nearly isobaric flame in which most of the reaction occurs in a narrow zone that can be approximated as a surface. In the mixed mode combustion there is partial premixing of flames as well as diffusion also occurs. Such flames occur in many practical applications like in industrial burners, gas fired domestic burners, rocket burners and also gas turbine combustors. Although flows in combustors usually are turbulent, analysis of flame stabilization are often based on equations of laminar flow. This may not be as bad as

it seems because in the regions of the flow where stabilization occurs, distributed reactions may be dominant, since reaction sheets may not have had time to develop; an approximation to the turbulent flow might then be obtained from the laminar solutions by replacing laminar diffusivities by turbulent diffusivities in the results. The important combustion phenomena which have received considerable attention in the recent years are flame lift-off mechanisms, lift-off height, lift-off velocity and blow off velocity. Study of these phenomena helps to fix the operating range or operating limits of a burner (Orfanoudakis et al, 2005).

Industries rely on heat from the burners in all combustion systems. Optimizing burner performance is critical to complying with stringent emissions requirements and to improve industrial productivity. Even small improvements in burner energy efficiency and performance can have significant impacts in a continuous operation, more so if the improvements can be used in other combustion systems and across industries. While tremendous advances have been made in understanding the fundamentals of combustion, the remaining challenges are complex. To make improvements, it is critical to understand the dynamics of the fuel fluid flow and the flame and its characteristics (Hatzia Apostolou, 1991). This can be achieved using a properly designed laboratory lantern. Hence the

importance of this project which is aimed at designing and constructing a simple, low cost and highly reliable biofuel lantern with less emission and high illumination.

In analysing flames burning in a mixture of biodiesel of known pressure and composition, two characteristic properties may be defined and measured, the burning velocity and the flame temperature. Flame temperature can be predicted from thermodynamic data by Bunsen in Germany in 1866. Historically, there have been two approaches to formulating the laminar flame propagation in premixed biodiesel:

- Thermal propagation: the mixture is heated by conduction to the point where the rate of reaction is sufficiently rapid to become self-propagating.
- Diffusional propagation: Diffusion of active species such as atoms and radicals, from the reaction zone or the burned biodiesel into the unreacted mixture causes reaction to occur.

Biofuels, such as biodiesel, offer benefits as a possible alternative to conventional fuels due to their fuel source sustainability and reduced environmental impact. Before they can be used, however, it is essential to understand their physical properties, combustion chemistry, and characterization of the exhaust due to a number of issues associated with fuel properties, for example, a lower heating value and higher cloud point than regular diesel. High viscosity of biodiesel may lead to poor atomization of the fuel spray and inaccurate operation of the fuel. Biodiesel may produce high NO_x emissions, depending on the feedstocks and blending ratios used to produce the fuel, variations in chemical properties may also be an issue. Biodiesel is a liquid biofuel obtained by chemical processes from vegetable oils or animal fats and an alcohol that can be used in laboratory lantern alone or blended with diesel oil. Biodiesel is defined as a mixture of long chain mono alkyl esters from fatty acids obtained from renewable resources, to be used in laboratory lantern. Blends with diesel fuel are indicated as "Bx", where "x" is the percentage of biodiesel in the blend. For instance, "B5" indicates a blend with 5% biodiesel and 95% diesel fuel (Nwadike et al, 2014).

Biodiesel has gained prominence as an attractive fuel in recent years. It is expected that biodiesel will be used extensively in the future because it offers the following characteristics.

1. Renewable and non-petroleum-based
2. Lower greenhouse gas emissions
3. Less toxic
4. Biodegradable
5. Lower emissions of PM, CO, hydrocarbons (HCs), and other air toxins

Fundamental Principles of Biodiesel Combustion

The fundamental principle of biodiesel combustion is an isothermal combustion process, which is achieved by the progressive introduction of an auto igniting biofuel into an expanding air charge at such a rate that the expansion of the air and the heat created by the combustion process balance thereby achieving a constant temperature expansion process (Anand et al, 2008).

In this biodiesel laboratory lantern the isothermal combustion process is described as follows. 'Firstly, a finely dispersed fuel is gradually introduced from outside into the reservoir, it is then compressed, and it ignites itself because the mass of air has been heated way above the temperature

necessary for ignition of the fuel. Simultaneously to the gradual introduction of the fuel, occurs an expansion of the air mass, which is controlled in such a manner that the cooling of the air charge due to its expansion is exactly counterbalanced by the heat generated through the combustion of the individual particles being introduced. In this fashion, the combustion does not result in an increase of temperature, but exclusively in the production of useful work (Sakar, 2009).

The biodiesel combustion process has been delineated in significant detail by various researchers in terms of its flame structure, combustion stoichiometry and flame temperature, on the basis of experimental work employing optical diagnostics. A conceptual model of diesel combustion arising from such optical experiments is relevant to the discussion of pollutant formation with regards to the effects which different fuels have on the heat release patterns and formation of pollutants (Cheng et al, 2006).

An important implication of this combustion model is that even during the later mixing-controlled stages of combustion, the fuel undergoes a two stage oxidation process. The fuel undergoes oxidation firstly in a rich premixed oxidation process at equivalence ratios between $\Phi=2$ and $\Phi=4$ in the regions situated immediately downstream of the lift off length of the jet, before undergoing further oxidation in the presence of sufficient amounts of air within the diffusion flame located throughout the periphery, but most prominently at the downstream end of the combusting jet. The phenomenological description of diesel combustion in terms of flame structure, stoichiometry and temperatures has suggested that the way in which the combustion process takes place may be critical to the processes by which the formation of pollutants occurs (Cheng et al, 2006).

Study Significance

Considering the unavailability of combustion laboratories in South Eastern Nigeria, which is militating students with interest in combustion to embark on combustion related researches, this project would serve as a laboratory tool for carrying out series of combustion related experiments. Different biofuels have been produced in Nigeria from variety of bio materials. The combustibility / efficiency of these untested biofuels can be tested using this lantern, and their flame temperatures and structures measured for further studies and their industrial applications.

2. Materials and Methods

The following materials were used in the construction of the lantern; 2mm mild steel sheet, a 1mm nozzle, 10mm and 8mm copper pipe, pneumatic valve, 0-10bar pressure gauge, manual pump and control knob. The input analogue to digital converter PORTA of the microcontroller senses the voltage from the output of the LM35 analogue temperature sensor which enables the microcontroller unit through the program written into its memory read the input temperature of the lantern and output the accurate result on the LCD screen. The microcontroller in this design takes charge of reading, converting the analogue temperature read by the LM35 to digital voltage and also displays the output temperature on the LCD. Also the pic16F877A microcontroller through the collector of the BC548 transistors senses the logic on its input pin in order to determine is the liquid level is beyond the required level, sends logic 1 to trigger the alarm unit. Step down transformer connected to the input and output

produces low voltage 12 volts. This low voltage is rectified to get DC voltage which supplies power to relay driver circuit and control circuit. This work also described the development

of a unique lantern fuelled by 100% biofuel for its illumination and its comparative performance with respect to a standard kerosene lantern.

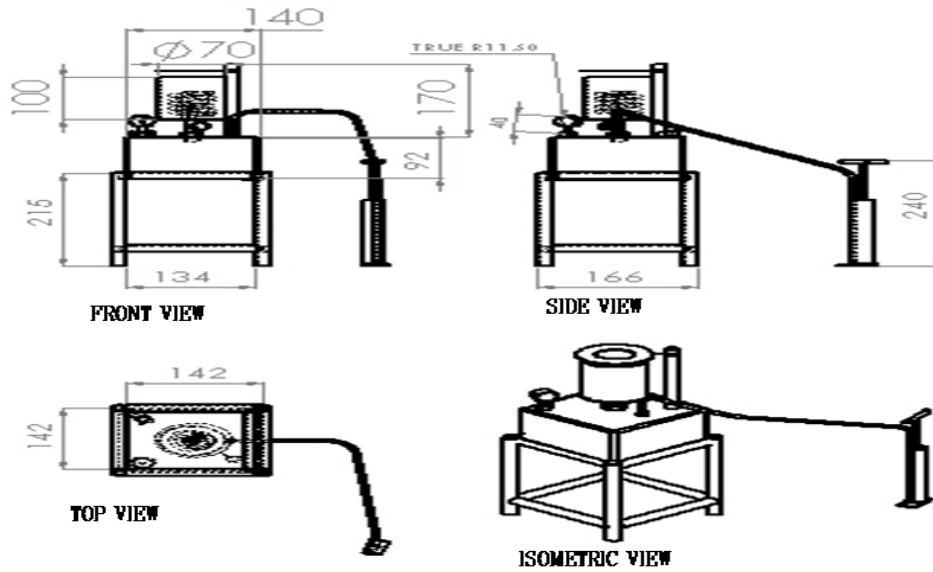

Fig 1: Different Views of the Lantern

Design of the Microcontroller Unit

Design of the Power Supply Unit

The power supply is made up of the transformer, the rectifier diode, the smoothing capacitor and the voltage regulator as shown in figure 2.

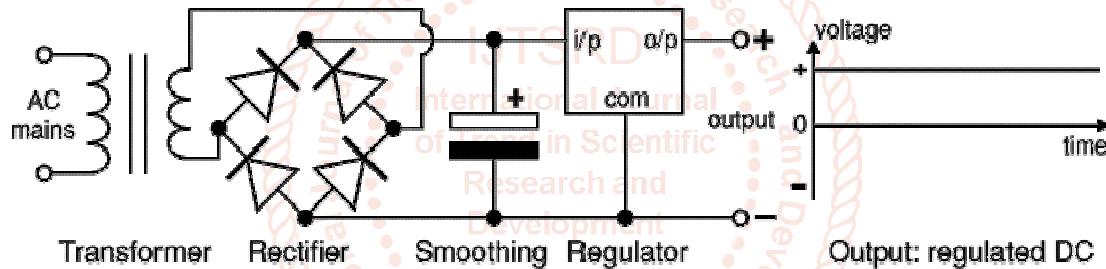

Fig 2: Wiring of the Power Supply Unit

The transformer used for the design is a 220V/12V, 50Hz, 300mA step down transformer. It was chosen to because the output voltage was safe and also enough to power the overall circuit which needed just 5V for it to function.

The bridge rectifier diode used for the design has the following specification:

Forward voltage drop of $0.7V \times 2 = 1.4V$ 1

Max current of 1A.

Since a voltage of 12Vrms AC is supplied by the transformer

The equivalent DC Voltage in R.M.S is given by

$$\begin{aligned} V_{rms} (DC) &= V_{rms} (AC) - \text{Forward Voltage Drop of Diode} \\ &= 12V - 1.4V = 10.6V \text{ DC} \end{aligned} \quad 2$$

$$\begin{aligned} \text{There the peak Voltage } V_p &= V_{rms} (DC) \times \sqrt{2} \quad 3 \\ &= 10.6V \times \sqrt{2} \\ &= 14.998V \end{aligned}$$

In this design 15Volts was used in subsequent calculations.

Choice of Smoothing Capacitor

In other to minimize ripple to at least 10%, an electrolytic capacitor was used and its value was calculated using the formula

$$C = \frac{5I_o}{fV_p} \quad 4$$

Where C = Capacitance of the capacitor;
 I_o = output or load current of transformer;
 f = frequency; and
 V_p = peak voltage.

For the transformer, output current $I_o = 300\text{mA}$, frequency is 50Hz and V_p of 15V was used. Therefore fixing in our values we have that

$$C = \frac{5 \times 300 \times 10^3}{50 \times 15}$$

5

$$C = 2000\mu\text{F}$$

Therefore a $2200\mu\text{F}$ capacitor was chosen for effective reduction of ripple.

The voltage regulator KA 7805 was employed in the design to effectively regulate the output voltage going into the circuit to 5V . The specification is as follows:

Regulated output voltage 5V

Output current 1A .

Design of Pic Microcontroller Unit

PIC 16F877 is one of the most advanced microcontroller from Microchip. This controller is widely used for experimental and modern applications because of its low price, wide range of applications, high quality, and ease of availability. It is ideal for applications such as machine control applications, measurement devices, study purpose, and so on. The PIC 16F877 features all the components which modern microcontrollers normally have. The PIC16F877 chip is shown in figure 3.



Fig. 3: PIC 16F877A

In this design PIC16F877A was used.

Analog Features

1. 10bit, up to 8 channel A/D converter.
2. Brown Out Reset function.
3. Analog comparator module.

Pin Diagrams

PIC16F877 chip is available in different types of packages. According to the type of applications and usage, these packages are differentiated. The pin diagrams of a PIC16F877 chip in different packages is shown in the figure 4.

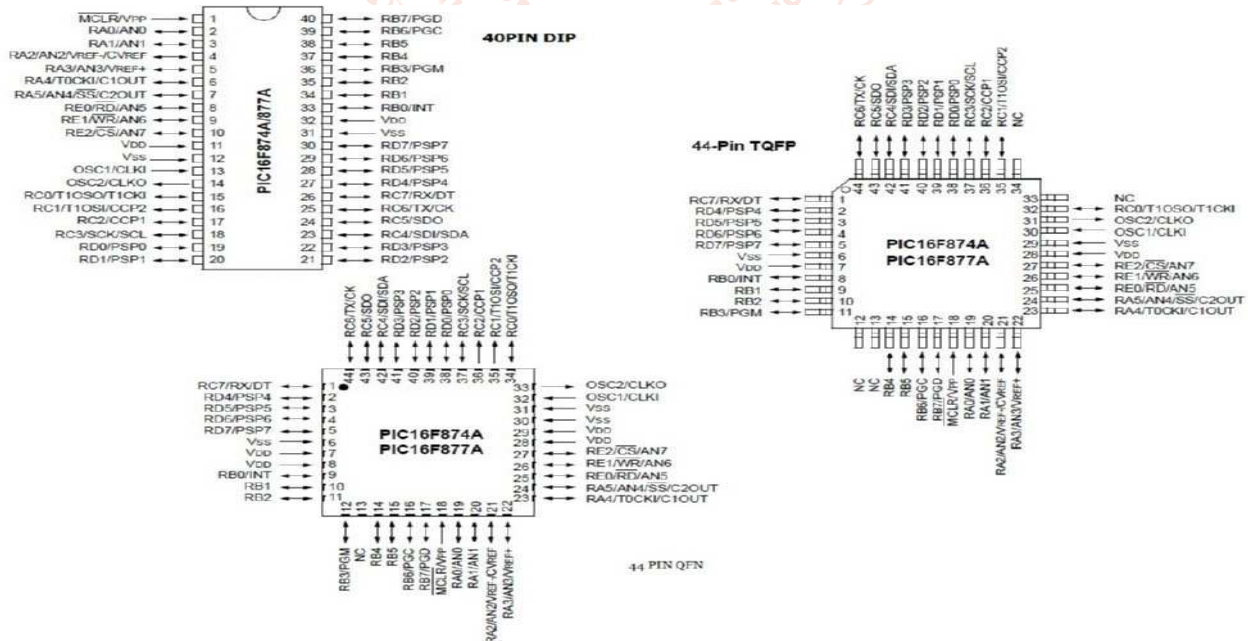

Fig 4: Pin Diagrams of PIC 16F877A chip Input/output ports

PIC16F877 has 5 basic input/output ports. They are usually denoted by PORT A (RA), PORT B (RB), PORT C (RC), PORT D (RD), and PORT E (RE). These ports are used for input/output interfacing. In this controller, "PORT A" is only 6 bits wide (RA-0 to RA-7), "PORT B", "PORT C", "PORT D" are only 8 bits wide (RB-0 to RB-7, RC-0 to RC-7, RD-0 to RD-7), "PORT E" has only 3 bit wide (RE-0 to RE-7).

Table 1: PIC16F877 Chip input/output ports.

PORT-A	RA-0 to RA-5	6 bit wide
PORT-B	RB-0 to RB-7	8 bit wide
PORT-C	RC-0 to RC-7	8 bit wide
PORT-D	RD-0 to RD-7	8 bit wide
PORT-E	RE-0 to RE-2	3 bit wide

All these ports are bi-directional. The direction of the port is controlled by using TRIS(X) registers (TRIS A used to set the direction of PORT-A, TRIS B used to set the direction for PORT-B, etc.). Setting a TRIS(X) bit '1' will set the corresponding PORT(X) bit as input. Clearing a TRIS(X) bit '0' will set the corresponding PORT(X) bit as output.

(If we want to set PORT A as an input, just set TRIS(A) bit to logical '1' and want to set PORT B as an output, just set the PORT B bits to logical '0'.)

Design of Temperature Sensor and Analogue to Digital Converter Unit

The LM35 Temperature Sensor used in this design has Zero offset voltage, which means that the Output = 0V at 0 °C. Thus for the maximum temperature value (150 °C), the maximum output voltage of the sensor would be 150 * 10 mV = 1.5V.

The ADC module of PIC microcontroller have usually 5 input for 28 pin devices and 8 inputs for 40 pin devices. The conversion of analog signal to PIC ADC module results in corresponding 10 bit digital number. PIC ADC module has software selectable high and low voltage reference input to some combination of VDD, VSS, RA2 and RA3.

In this project we converted the analog input to channel 1 to 10 bit digital number with low voltage reference (Vref-) 0v and high voltage reference (Vref+) 5V. The output is read and shown on the LCD. The Vref- and Vref+ can be changed by configuring the ADCON1 register.

$$OV=0000000000$$

$$5V=1111111111$$

$$\text{Resolution} = (V_{ref+} - V_{ref-}) / ((1024 - 1)) \text{ (as it is 10bit ADC)}$$

$$= 5 / 1023 = 4.887\text{m}$$

Thus, it means that for a change in 4.887mV, the binary output changes by 1. The Analog output voltage of LM35 temperature sensor is given to the Analog Input pin AN1 (Pin 3) of the PIC Microcontroller. The result of the 10-bit Analog to Digital (A/D) Conversion is read using the function ADC_Read(1). This 10-bit digital value is then converted to the corresponding voltage by multiplying with 0.4887. Then the Voltage is converted to corresponding character to Display it in LCD. The interfacing diagram is shown in figure 5.

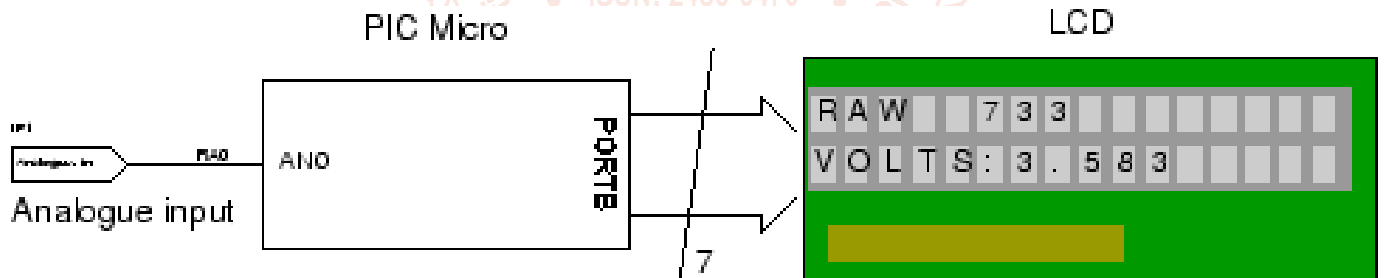

Fig 5: Showing the interfacing of analogue input to the pic

Design of the Fuel Level Sensor Unit

The design of the fuel level detector unit was achieved using BC548 NPN transistor connected via collector to the microcontroller unit. Due to the combustion of fuel, anytime the fuel goes below the sensor probes, the alarm is triggered.

Design of the LCD Display Unit

A 16 by 2 liquid crystal display was used to read out the values of the temperature read by the LM35. The LCD was interfaced to the microcontroller in a 4bit mode as seen in figure 6.

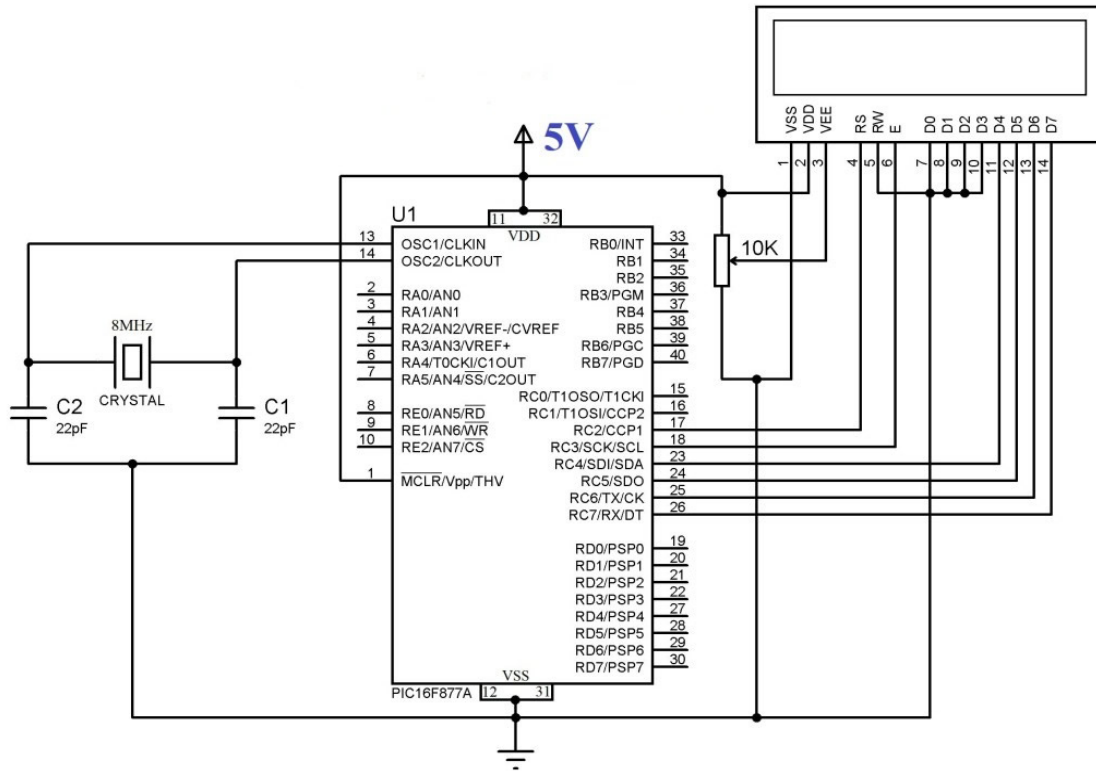

Fig 6: Interfacing LCD with Microcontroller

In this mode the 8-bit ASCII data is divided into 2 parts which are send sequentially through data lines DB4 – DB7 with its own data strobe through the E line. The idea of 4-bit communication is to save as much pins that is used to interface with LCD. The 4-bit communication is a bit slower when compared to 8-bit. The speed difference is only minimal, as LCDs are slow speed devices the tiny speed difference between these two modes is not significant. In this design, six (6) pins of PORTB of the microcontroller was used to drive the LCD display. Mikro C Pro provides built in libraries for interfacing LCDs with HD44780 compliant controllers using 4 bit mode data transmission.

The Alarm Unit

The alarm unit is made up of a buzzer, connected to pin 2 of PORT D of the pic16F877A microcontroller. The buzzer is activated whenever the input pin 1 of PORT D goes high when the liquid level is low thereby disconnecting the two wire probes inserted into the liquid.

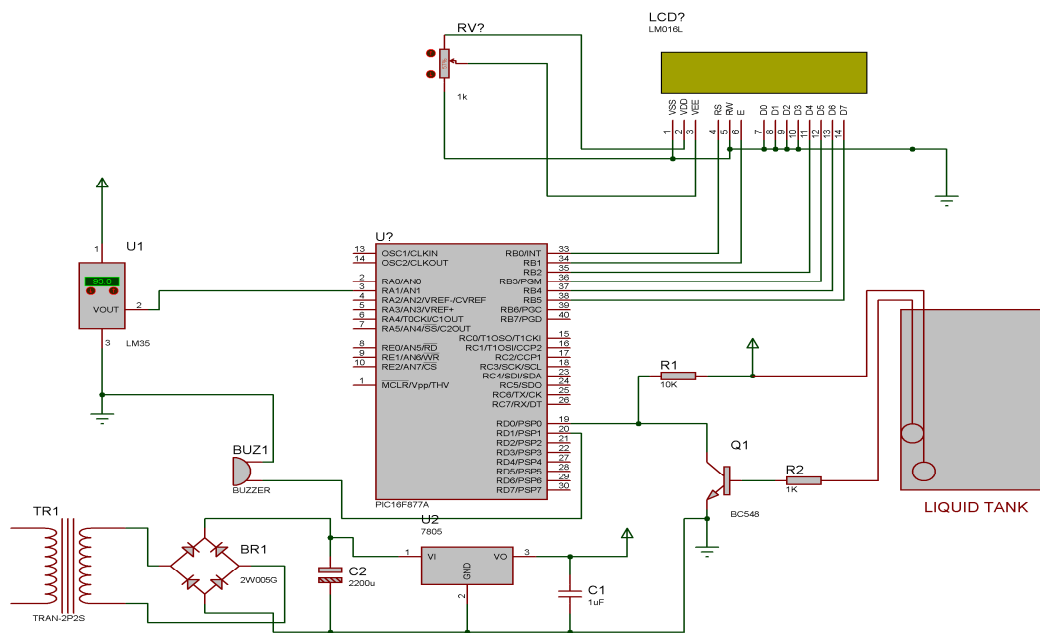

Fig 7: Complete Circuit Diagram

Software Design

C programming language was used to write the code for the Microcontroller based stabilizer, Mikro C compiler was used to compile the source file while Top win programmer was used in programming the code into the chip.

Operational Principle

When biofuel is poured into the reservoir through the inlet, the biofuel in the reservoir gets pressurized through the valve attached to the reservoir using a manual pump. On pressurizing the biofuel, it gets atomized. The control knob is

opened to enable the atomized biofuel travel from the reservoir to the nozzle through the coil tube. The lantern is ignited through the nozzle and the flame heats up the fuel in the coil tube making it superheated. The superheated biofuel comes out of the nozzle in gaseous form to maintain a stable flame.

The complete circuit diagram of the LANTERN THERMOMETER is shown in figure 7. The operation of the circuit will be explained using the complete circuit diagram as a reference.

The input analogue to digital converter PORTA of the microcontroller senses the voltage from the output of the LM35 analogue temperature sensor which enables the microcontroller unit through the program written into its memory read the input temperature of the lantern and output the accurate result on the LCD screen.

The microcontroller in this design takes charge of reading, converting the analogue temperature read by the LM35 to digital voltage and also displays the output temperature on the LCD.

Also the pic16F877A microcontroller through the collector of the BC548 transistors senses the liquid level is beyond the required level, sends logic 1 to trigger the alarm unit.

Step down transformer connected to the input and output produces low voltage 12 volts. This low voltage is rectified to get DC voltage which supplies power to relay driver circuit and control circuit.

Conclusion

The lantern was successfully designed, fabricated and tested with biodiesel produced from cow tallow and kerosene. It can combust varieties of biofuels. During the performance analysis, the fuel which is mixed with air before ignition, produces laminar premixed flame. The combustion rate was seen to be emitting blue laminar cubic shaped flame. The lantern will help to solve many combustion problems in the laboratory such as temperature reading with the help of microcontroller made of pic 16F877 which takes temperature reading between 0-150°C. It would serve as a laboratory tool for carrying out series of combustion related experiments and encourage students with interest in combustion to embark on combustion related researches. The aim of this project which was to construct a simple, low cost and highly reliable biofuel lantern with less emission and high illumination was achieved because the lantern when tested with 1litre of biodiesel produced from

cow tallow, combusted for over 10 hours in a stable flame manner as the burner was attached to the coil tube to ensure its stabilization. From the experimental readings, it was observed that decrease in reservoir pressure, results to decrease in volume flow rate of the fuel and decrease in flame height as the time of combustion increases.

Acknowledgement

We acknowledge the Tertiary Education Trust Fund (TETFund) for funding this research work through Institution Based Research (IBR) grant.

References

- [1] Abbas, T, Charoenduk, J., Costen, P. and Lockwood, F. C. The performance of pulverised coal flames in a simulated combined cycle unit. *Comb. Flame*, 11, pp. 111-123, 1997.
- [2] Anand R. Mahalakshmi N. V. Simultaneous reduction of NO_x and smoke from a direct- injection diesel engine with exhaust gas recirculation and diethyl ether, *Proc. Inst. Mech. Eng. Part D, J. Automobile Engineering*, 221(1): 109-116. 2008.
- [3] Cheng A. S. Upatnieks Mueller C. J. Investigation of the impact of biodiesel fueling on NO_x emissions using an optical direct injection diesel engine, *international journal engine research*, 7:297-318. 2006.
- [4] Hatziapostolou A. Swirling flows in direct-injection diesel engines, PhD Thesis, Imperial College of Science, Technology and Medicine, Department of Mechanical Engineering, 1991.
- [5] Nwadike Emmanuel Chinagorom, Achebe Hubert Chukwunonso, Ezeliora Chukwuemeka Daniel, Azaka Onyemazuwa Andrew. "FTIR analysis for groundnut seed oil, cow tallow oil and castor seed oil for biodiesel production ". *American Journal of Mechanical Engineering and Automation* 2014; 1(4): 38-41.
- [6] N. G. Orfanoudakis, A. Hatziapostolou, K. Krallis, E. Mastorakos, K. Sardi, D. G. Pavlou & N. Vlachakis. Design, evaluation measurements and modelling of a small swirl stabilised laboratory burner. *IFRF Combustion Journal Article* Number 200510, December 2005 ISSN 1562-479X.
- [7] Sakar S. (2009). *Flames, fuels and combustion*, 3rd edition, University press India.